

Serendipity Blackmagic



User Guide

Serendipity Blackmagic User Guide V1.2.01

Written 12th August 2004

Updated 6th December 2004
For Version 3.0.01

Updated 10th February 2005
For Version 3.0.02

Updated 12th August 2005
For Version 3.1

Updated 16th December 2005
For Version 3.2

Updated 28th April 2006
For Version 3.2.01

Copyright 2006 Serendipity Software Pty Ltd.

Reproduction of any part of this manual is strictly forbidden without prior written permission from Serendipity Software. All company names, product name and trademarks mentioned in this manual are the property by the respective company.

Important Notice

Every effort is made to make sure that the information contained within this manual is correct. Serendipity Software cannot be held responsible for any errors contained within this manual and will not enter into any negotiations for claims of compensation relating to actions taken in this manual for any reason what so ever.

Serendipity Software are constantly making improvements to the software and as such this manual may not contain the latest information. Every effort is made to maintain the manual and for the latest version please check the website www.serendipity-software.com.au. If you find any errors contained within this manual please detail them in an email to support@serendipity-software.com.au.

Table of Contents

Serendipity Blackmagic User Guide V1.2.01	2
Copyright 2006 Serendipity Software Pty Ltd.....	2
Important Notice	2

Serendipity Blackmagic

Product Overview.....	12
-----------------------	----

Installation

Overview	14
What's on the CD.....	14
Windows.....	14
Installing the Dongle Driver.....	14
Installing Serendipity Blackmagic	14
Installation of Serendipity Agent	15
Upgrade from V2 to V3 - Windows.....	15
Removing the old dongle driver.....	15
Installing the software upgrade	15
Macintosh	15
Installing the dongle driver	15
Installing Serendipity Blackmagic	16
Creating Dock Start Icons	16
Upgrading from V2 to V3 - Mac.....	16
Backing up V2.....	16
Database Manager.....	16
Saving database and ICC profiles	16
Using the database from V2	16

Running the software - A Tutorial

Overview	18
Starting the Server.....	18
Starting the Client.....	18
Configuring manually	18

Serendipity Blackmagic Server

Overview	22
Server options.....	22
.....	22
File menu.....	22
Startup Options.....	22

The Serendipity Client

Overview	24
Look and Feel.....	24
Workbench	24
Menu Items.....	24
Monitor.....	25
Edit	25
Use.....	25
Re-ordering Tabs.....	26

Monitor Modules

Overview	30
RIPMonitor.....	30
The View	30
Context menus.....	30
Context Menu options available for jobs.	30
Buttons	31
Virtual Press	31
History Options	31
QueueManager	32
View Options.....	32
Actions	33
Queue Status.....	35
Thumbnail	36
DropZone	36
Status	36
ClientLog.....	36
Filtering options	37
Display Options.....	37
ServerLog	37
Display Options.....	38
Cluster Status.....	38

Dot Gain

Overview	42
----------------	----

Gradation Curve

Overview	44
Curve View Options.....	44

ICC Tweak Set

Overview	46
Options	46

Job Genie

Overview	48
Tasks.....	48

Ordering	48
Tab 1 - Collect Files	48
Actions	48
Definitions	49
Tab 2 - Filename Break Down	49
Separator Options	50
Tab (3) - Jobname + Plate	50
Job Grouping	50
Plate Identification	51
Plate Mapping	51
Tab (4) Display	51

Output

Overview	54
Queue	54
Destination	54
Collating	55
Duplexing	55
Nesting	56

Pagesetup

Overview	58
Pagesetup Modules.....	58
Output.....	58
Custom Settings.....	58
Publish.....	58
DropFolders.....	58
Printers	59
.....	59
TCP Port.....	59
Colour Correction.....	59
ICC Profiles.....	59
Colour Keys.....	60
Screen Printing	60
Output Screening.....	61
Input Screening	61
Postscript Options	62
Resampling.....	62
Logo	62
Effects.....	62
Sheet.....	63

Pagesetup Pools

Overview	66
Publish.....	66
DropFolders.....	66
.....	66
Printers	66

.....	66
TCP Port.....	66
Job Queuing.....	66
Pool Type	66
Pagesetups	67
Context menu	67

Paper Profile

Overview	68
Context Menu Options	68
Sort Options.....	68
Patches.....	68
Graph.....	69
Manual Entry Procedure.....	69

Regular Expression

Overview	72
What is a Regular Expression	72
Expressions.....	72
Match List	72
String Entry	72
Buttons	73

Replace Colour Set

Overview	76
Tabs	76
Tab 1 - Process	76
Tab 2 - Exact	76
Tab 3 - Partial.....	76
Tab 4 - Position	76
Tab 5 - Remaining.....	76
Renaming Options.....	77
Column Headings.....	77
Colour Adjustment	77

RIP

Overview	80
Driver	80
Polling	80
Connection	80
File Transfer Priority.....	81
Paths	81
AutoProofing.....	81
Printing	81
Criteria.....	82
Advanced.....	82
Job Filtering.....	82
Testing.....	82

Signature Group

Overview	84
Tool Bar.....	84
Display Options.....	85
Signatures	85
Press Sheet.....	85
Plate Options	86
Pages.....	86
Grid Attributes.....	86
Page Attributes	86

Special Colour Set

Overview	88
Toolbar	88
Column Headings	89
Colour Adjustment	89

Soft Proof

Overview	92
Starting the SoftProof Tool	92
View Options.....	92
Signatures	92
File Menu	93
Additional Menu View Options.	93
Windows.....	93
Contextual Menu Items	94
Tools.....	94

Densitometer

Overview	96
Measure Targets	96
Export.....	96
Miscellaneous options	96
Colour List.....	97

Spectrophotometer

Overview	98
Column Headers	98

Lineariser

Overview	100
Wizard	100
First Step	100
Second Step.....	100
Final Step.....	100
Lineariser window	101
Advanced Options	101

Cluster Manager

Overview	102
Master.....	102
Slave Nodes.....	102
Column Headings	102

Archiver

Overview	104
File Menu	104
Edit Menu (and context menu).....	104

FlipBook

Overview	106
Starting the FlipBook	106
Pages.....	107
Options	107
Menu Items.....	107

MonitorCalibrator

Overview	110
Starting the MonitorCalibrator	110
Options	110

Application Menu Items

Overview	112
Submit Files.....	112
Submit Files For Deimposition	112
Test Prints.....	112
Connect To Server.....	112
Authorisation	112
ChatterBox	112
Broadcast Message	113
Download PPD.....	113
Quit.....	113

System Settings

Overview	114
Server Settings.....	114
Client Settings	114
Server Info.....	115

Calibration Guide

Overview	118
Equipment needed	118
Configuring a Pagesetup	118
Creating a Paper Profile	118
Print Density Chart.....	119

Measure the Patches	119
manual entry	119
D and V values	119
Sifting the results.....	119
Select the Paper Profile	119
Ink Limits	119
Linearisation.....	120
Printing the Linearisation Chart	120
Reading the Linearisation Chart.....	120
Submitting the curve	121
Manual Entry.....	121
ICC Profiles.....	121
Assess the chart	122
Placing the profile	122
Match Profile.....	122
Tuning calibration	123
Correction LUT	123
Dot Gain	123
Tweak Set.....	123
RGB Workflows.....	123
Expert section - Manual dot selection of Paper Profile.....	123
The Printers	124
Measuring the patches	125
Choosing the patches.....	125
Assessing the print	125
Evaluating the densities.....	125
The Graph.....	126
Printing a vignette	126
Practical Example.....	127
Summary	129
Lineariser - Expert Section.....	129
Yule Nielsen Number	129
Maximum Densities Override	130
Pros and Cons.....	130
Colour Management diagram.....	131

Screen Printing

Overview	132
Configuration	132
The Pagesetup	132
The Paper Profile.....	133
Ink Limiting.....	133
Linearisation.....	133
Summary	134

Using the Xrite DTP20 Pulse

Overview	136
Lights and Sounds	136

Setting up a DoubleProof or SpinJet

Overview	138
Configuration	138
The Pagesetups	138
The Output.....	138
The Test Page	139
Printing the job	139
Printer specifics	140
Calibration	140
Limitations	141

Glossary

Copyright Notices

Serendipity Blackmagic

Product Overview

Serendipity Blackmagic is used to proof post RIP data to either an output device such as an inkjet printer or to a file format such as PDF. Serendipity Blackmagic runs as a server and client configuration. The server runs on a computer on the network and is protected by a USB dongle. This dongle licenses the level of software and the input and output drivers purchased. The client can run on the same computer or any other supported computer on the network, whether that be local (LAN) or remote (WAN). It connects to the server using the standard network protocol TCP/IP and is used as the configuration tool and monitoring application to the server. The Client is not licensed and you can run as many as you wish on the network.

Serendipity Blackmagic has an input filter for most of the major manufacturers proprietary RIPs. The input filters read the native RIP format and understands how jobs are assembled, the plates associated with a job and the directory structure. Some RIPs have databases and impositions which are also read and understood. Because it is the post RIP data the files that are proofed are the same files that are output as the final job on the press and thus data integrity is maintained. The files are RIPped once by the proprietary RIP and then output as many times as desired. The jobs reside on the RIP and are monitored by the Serendipity Blackmagic sever. These jobs are shown by the Client in a RIPMonitor with all of the associated plates stitched together. The files can be selected and submitted for processing by the sever as desired or it can be configured to process jobs automatically. At that point the jobs are copied (spooled) over from the RIP to the server leaving the original untouched. Once the whole job is spooled the server begins to work on the files.

The first process to take place is Imaging. This interprets the file format, completes any imposition assembling required (for supported imposition RIPs) or any merging of CT/LW files, preserves any screening on the files and samples the jobs resolution to change it to that of the output format configured. At that point an intermediate file format is created which is called the Image File.

This imaged file can be viewed using the Soft Proof Utility. The format maintains all the plates associated with the job and is viewed at the full output resolution. See “Soft Proof” on page 92 for more information. The intermediate file can also be re-submitted at any time for processing again to the same

output or a different one. There is no need to spool and interpret the job again.*

After the imaging process has completed the job is passed to the rendering engine. This takes the imaged file and creates the file ready for output. This process involves applying any output characteristics such as orientation, cropping, colour management (ICC Profiles) etc. and creation of the format configured whether that is for an inkjet or a file format such as PDF. The intermediate format can be rendered as many times as desired. Each time, any of the output characteristics can be changed prior to rendering again.

The job is then submitted for printing to the output device or file format. Multiple output queues can be created and multiple devices printed to simultaneously. Most of the output devices supported use a direct printer driver and therefore the server has more control of them such as selecting specific media and printing directions etc.

The Client monitors the whole process from start to finish showing jobs progress in a QueueManager and Queue Status windows. Jobs can be managed separately by placing a job on hold, releasing a job, cancelling or promoting as desired. Or the processes (queues) can be paused at any time holding all jobs from Spooling, Imaging, Rendering or Printing. If a job fails the error can be examined, rectified and the job retried. There are logs that report all server and client functionality and job information from first detection on the RIP to final output. The logs can be searched, filtered or saved to a file.

The system creates a database of all the configurations, calibration curves etc. This database can be backed up on demand or automatically so a working copy is always available. It can be copied to any other Serendipity Blackmagic as a whole database or as individual items.

* This applies to any output characteristics. If any changes are required to the imaged file e.g. changing of plates, resolution etc. then the file will need to be submitted again from the RIPMonitor.

Installation

Overview

This section describes the installation process for each platform in turn. The Software is supplied on one CD for the Macintosh, Linux and Windows versions, with the Sun and SGI versions on another CD. The Macintosh, Linux and Windows versions come with a Dongle and require a dongle driver to be installed. The SUN and SGI versions use a software license so no dongle driver is required. If you have an existing installation of the software you are given the chance to upgrade that installation where all configurations are preserved.

What's on the CD

The CD contains all the elements to run Serendipity Blackmagic and associated programs. They are divided into directories and detailed below.

- Agent - Contains the Agent software for all supported platforms. Choose the subdirectory that matches the required operating system.
- Docs - Contains documentation.
- Dongle - Contains the dongle drivers for Linux, MacOSX and Windows.
- Drivers - Contains the Megarip PPDs for all supported platforms.
- html - Contains the information required for the web browser install. This normally automatically launches your default browser for the install to begin.
- irix - Contains the Serendipity Blackmagic package for the Irix (SGI) system.
- linux - Contains the Serendipity Blackmagic and AppleTalk packages for Linux.
- macosx - Contains the Serendipity Blackmagic package for MacOSX.
- Serendipity Client - Contains the Serendipity Client for all supported platforms.
- solaris - Contains the Serendipity Blackmagic package for the Sun Solaris system.
- testprn - Contains Serendipity internal test prints.

- windows - Contains the Serendipity Blackmagic package for Windows.

Windows

We will make a fresh installation of the windows version step by step. If you are upgrading, see "Upgrade from V2 to V3 - Windows" on page 15

Installing the Dongle Driver

The first thing to do is to install the dongle driver. To do this follow the instructions below.

1. Remove all USB SuperPro dongles.
2. On the CD navigate to the dongle/windows directory.
3. Double click the SSD5411-32bit.exe file to launch the installer.
4. Click Next to continue with the installation
5. Read the License Agreement, select the accept option and click Next to continue with the installation.
6. Choose the folder location for the driver and click Next.
7. Choose Complete and click Next.
8. Click Install to install the driver.
9. Click Finish once the installation is complete.

Installing Serendipity Blackmagic

Once the dongle driver is installed you can install the Serendipity Blackmagic. If you are viewing the browser install with Explorer you can run the installer direct from the browser. If you are using another browser then you need to run the installer direct from the CD.

1. Either select and run the installer from the browser (Explorer only) or go to the CD and navigate to the windows directory and run blackmagic.msi
2. Select Next to continue with the installation.

3. Read the License Agreement and click Yes to continue with the installation. Click No if you do not agree with the license agreement to terminate the install.
4. Click Next to choose the default installation location. If you wish to change the location, select Browse, choose the location and click OK followed by Next to continue.

note - You can type your own path and the installation program will make the folder for you providing your chosen location has valid permissions. Use back slashes (\) to separate directories.

5. Choose Full Install and click Next to continue.
6. Choose the name for the Start Bar and Icons and click Next to continue.
7. Click Finish once the installation has completed.

Installation of Serendipity Agent

If you are polling a RIP that runs on a Windows based machine, then the most efficient method is to use the Serendipity Remote Agent. This turns as a service on the windows machine where the RIP is and the Serendipity Blackmagic communicates with the Agent to poll and transfer jobs.

1. Go to the CD and navigate to agent/windows.
2. Run agent.msi to launch the installer.
3. Click Next to continue
4. Read the License Agreement and select Yes to continue the installation. Select No if you disagree with the License to terminate the install.
5. Select the installation directory. Choose Browse if you want to install it somewhere other than the default location. If the folder does not exist the installation will create it for you provided there are sufficient permissions in the chosen location. Then select Next to continue.
6. Make sure the Agent component is selected and click Next to begin installation.
7. Click Finish when the installation is complete.

Upgrade from V2 to V3 - Windows

When upgrading Serendipity Blackmagic from version 2 it is strongly recommended that the database and ICC profiles are backed up prior to the install. See “Backing up V2” on page 16

Removing the old dongle driver

First thing to do is to uninstall the current dongle driver and install the new one.

1. Make sure that the Server and Client are not running and remove any dongles connected to the PC.
2. On the CD go to dongle/windows/olddriver/WIN_NT and run the program SETUPX86.EXE
3. Choose Functions - Remove Sentinel Driver and confirm OK when prompted.
4. Once driver is successfully removed quit the program and restart the computer.
5. Once the computer has started again follow the instructions on installing the dongle driver above.

Installing the software upgrade

1. On the CD navigate to the windows directory and run the blackmagic.msi program.
2. Click Next to continue
3. Read the License Agreement and click Yes to continue. Click No not to accept the agreement and exit the install.
4. Select the directory where version 2 is installed and click Next
5. Select Upgrade and click Next.
6. Choose the name for the Start bar and desktop icons and select Next to begin installation.
7. Click Finish when the installation is complete.

Macintosh

Administrator rights required for the installation of the Macintosh version. If you are upgrading from V2 to V3 then see “Upgrading from V2 to V3 - Mac” on page 16.

Installing the dongle driver



From Version 3.2.01 there is no separate dongle driver to install. The driver is installed as part of the general installation package.

For versions prior to this please consult the respective manual for Dongle installation instructions.

Installing Serendipity Blackmagic

1. Go to the macosx directory and double click the Serendipity Blackmagic.pkg to launch the package installation.
2. Select Continue
3. Read the License Agreement and click Continue
4. Select Agree
5. Choose the location to install the Software and click Continue (If you want a folder that does not exist then you need to create it through the finder).
6. Click Install to begin the installation.
7. Click Close once the install has completed.

Creating Dock Start Icons

To make it easy to start the Server and Client it is recommended that you create a shortcut on the Dock. To do this

1. Navigate to the install directory of the software.
2. Select the Serendipity Blackmagic program
3. Drag the program to the Dock and release in the desired position
4. Repeat the procedure with the Serendipity Client program
5. To remove the dock icons, drag them off the Dock onto the desktop and release.

Upgrading from V2 to V3 - Mac

When upgrading Serendipity Blackmagic from version 2 it is strongly recommended that the database and ICC profiles are backed up prior to the install. See “Backing up V2” on page 16

1. On the CD navigate to macosx and run the Serendipity Blackmagic.pkg
2. Click Continue
3. Read the License Agreement and click Continue
4. Select Agree to continue with the installation.
5. Select the drive and location to install the software into. Choose the folder Serendipity where V2 BlackMagic is currently installed
6. Select Upgrade to begin the installation.

7. Click Close when the installation is complete.

Backing up V2

Before you upgrade to version 3 from version 2 it is strongly recommended that you backup your current version of software. There are a number of methods you can use to do this which are detailed below.

Database Manager

You can use the database manager to create a backup of your configurations. Check the website under support for software updates of the latest version of the client. This has a fix for the database manager. Once you have upgraded to version 34 you can use the Archiver to install the database. See “Archiver” on page 104 for more info.

Saving database and ICC profiles

The other method is to save the database and ICC Profiles directory in another location before you upgrade. The database items are held in a directory called defaultss.dbd in the following location.

- Macintosh - /Applications/Serendipity/Black-Magic/lib/defaultss.dbd
- Windows - C:\Program Files/Black-Magic\lib\defaultss.dbd
- Linux/Sun/SGI - ~bmagic\lib\defaultss.dbd

ICC Profiles can be found in the following location.

- Macintosh - /Applications/Serendipity/Black-Magic/lib/ICC
- Windows - C:\Program Files\Black-Magic\lib\ICC
- Linux/Sun/SGI - ~bmagic\lib\ICC

If you make a backup of these you can restore them if the upgrade has problems.

Using the database from V2

The third method for upgrading and preserving the existing configurations is to make a fresh install in a new location leaving the version 2 install untouched. Then before you start the server for the first time copy the defaultss.dbd and ICC profiles into the new installation. See above for locations of V2 items. As

version 3 starts for the first time the database will be converted to the new structure.

Running the software - A Tutorial

Overview

Once the software is installed you need to launch the Server and Client and begin the configuration. The Server must be started first and allowed to complete its initialisation process before the Client can be launched. This is so that the client can connect to the server. Once the server and client are running we will configure a basic setup for a printer and configure the monitoring windows to view jobs processing.

Starting the Server

Plug the dongle in the USB port. Navigate to the directory where the software is installed and launch the Serendipity Blackmagic program. by double clicking on the Server icon.



Serendipity Blackmagic

The server window will appear showing information about the server software and the initialisation process will commence.

Starting the Client

Once the server has completed its initialisation you can start the client. To do this navigate to the directory where the software is installed and launch the Serendipity Client by double clicking on the Client icon.



Serendipity Client

This should connect to the server that is already running and display the Monitor as a small window in the centre of the screen (mac) or in the top left (windows). From here you can begin to configure the system or load a pre-configured setup.

Configuring manually

You can choose to configure your system manually or import a database and Monitor setup that has already been configured. (See “Archiver” on page 104 for importing a database and “Monitor” on page 25 for loading a pre-configured view.) This section will take you through the process of setting up a basic configuration to print a file to a printer and monitor the job through the process. For more detailed information about specific modules look at the relevant section of the manual.

There are three sections that we need to configure in order to process jobs from the RIP to the printer. These are a RIP where we poll the jobs, a Pagesetup where jobs are processed and an output where the print job is sent. Before we create a Pagesetup we must first create an output as each Pagesetup must be linked to valid output.

From the Serendipity Client select the Workbench from the Application menu. Select the Output from the data types list and create a new output. Configure the output to your requirements by selecting the appropriate driver for your printer. Choose a destination driver and enter the appropriate information. See “Output” on page 54 for more information on the options. Save and name the setup.

Once you have an Output configured and saved, choose Pagesetup from the Data types list and create a new one. You will be presented with a message telling you that the Pagesetup is not currently linked to a valid Output. The first stage is to select an output. Select OK and you will be presented with a chooser showing the output that you configured previously. Select the output and click OK. There will then be another message telling you that you have not selected all the necessary ICC profiles. Click OK to begin configuration of the Pagesetup. Configure the Pagesetup to match your requirements. The settings are based upon the Output driver selected. See the Pagesetup section on page 58 for more information on the options. Once you have your base configuration set up save and enter a name for the Pagesetup.

Now that you have a configured output path you need to setup a RIP (if you are taking post RIP data) so that files can be displayed and submitted for processing. Select RIP from the Data types list and create a new one. A warning message will appear telling you that there is no RIP driver selected. Select the appropriate

RIP driver, polling method and Path and save the configuration with an appropriate name. See “RIP” on page 80 for specific details on the options available.

Once the base configuration is completed the Monitor needs to be setup so that jobs can be managed throughout the system. From the Serendipity Client menu bar choose Window and select Monitor. (If the Monitor is not available under the Window menu item, choose Monitor under Application.) Resize the Monitor window to suit the size of the screen. Choose Tabs - New Tab from the menu and enter the name “Queues” for the new tab we are creating and click OK.

You now have a blank window with which to add modules for monitoring and managing your jobs. These Modules are available under the Layout menu item and we will add modules for the configuration we did in the Workbench for a RIP input, output and processing.

Choose Edit from the Layout Menu to place you in edit mode. Select Add QueueManager to place a new QueueManager on the Monitor window. Select anywhere in the window and drag it to the bottom left corner of the window. Select the top right corner of the QueueManager and resize it so it fills the whole of the bottom half of the Monitor. Next add a RIPMonitor and drag that to the right top corner of the window. Select the bottom of the window and resize it to the top of the QueueManager window. Next add a Thumbnail and leave it in the top left position. Then add four Queue Status windows, resizing and positioning each one on top of each other between the Thumbnail and RIPMonitor. Finally for this Tab add a Status Monitor and resize it to fill the available space below the Thumbnail. Your “Queues” Tab of the Monitor should look something like fig 1 below.

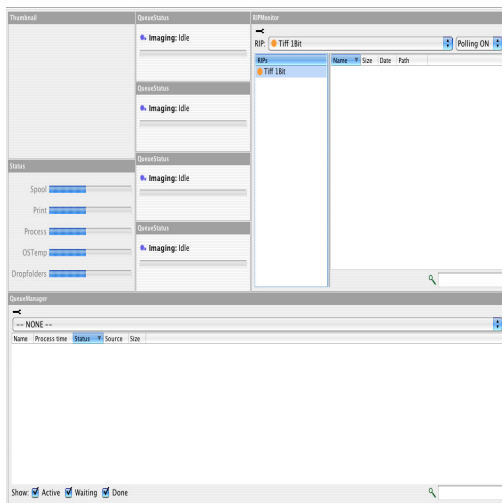

Now we have the main queues configured we are going to add a server and client log on another Tab. From the Tabs menu bar select New Tab, call it Logs and click OK. This will add a new Tab to the Monitor window and automatically select it. You now have another blank window. Again from the Layout menu options select Add Server log. Drag the window to the bottom of the tab and resize it so it covers half the area. Then add a Client Log and resize it to fill the top half of the window.

Now that we have positioned and sized the modules for use, we need to configure them for the best view. Choose Use from the Layout menu to come out of Edit mode. The Modules are now locked and cannot be moved or re-sized while in Use mode. You can move between the Tabs by selecting each as desired.

Select the Queues tab we created to configure the modules you added. If you look at the RIPMonitor in the top right corner you should see your RIP that you created. Resize the middle splitter bar by selecting and dragging it to the left so that the name of the RIP is still shown and there is more space on the right for your jobs. Resize the columns by selecting the bar between the names and dragging to the right until the desired width is reached. If you are only going to have one RIP configured then you can hide the side RIP list and the top RIP Menu selector.

Next we'll configure the QueueManager. Choose the QueueManager, right click and select Configure -> Queue Order. A window will appear showing the available queues on the left. Select all the queues by selecting the first queue, holding the shift key and selecting the last queue. Now drag all the queues from the left list to the right list and release. Now we need to re-order the list. Do this by selecting the Spool queue and dragging it to the top of the list and letting go. There are two red arrows that show the position the queue will be dropped in. Repeat for all the other queues so that they are in the order

Spool
Autodetect
Image
Render
Printer

Click OK to accept these and close the window. Right Click in the QueueManager again and choose Configure > List Colour and select a colour of your choice. Right click in the column headers and select Date. Then repeat for Width and Height. Select the Date and drag it left along the column headers and place it in between Status and Source. Now resize the

columns as desired by selecting the bar and dragging them as you did for the RIPMonitor. You will get a better idea of the column sizes when a few jobs are present in the QueueManager.

Next select the top Queue Status window, right click and choose Change Queue. This will display a chooser with all of the queues. Select the Spool queue and click OK. Now select the third Queue Status window and repeat choosing the Rendering this time. Finally repeat with the last Queue Status selecting the printer. This will give you the processing status in the order of files passing through the system i.e. Spooling, Imaging, Rendering and Output (printing).

Now you can run a test job to check that your configuration is working. From the menu bar choose Application/Test Prints. Select the internal test print, choose your Pagesetup and click submit. You should be able to see the job in the QueueManager with a status of "Waiting to Image". When the status changes to Imaging you will see it in the imaging Queue Status window which plots the progress of job and the Thumbnail will display a preview of the job. Once Imaging is complete the job will move to the Rendering queue and then onto the printer.

Finally if you change to the Logs Tab you can adjust the column sizes to display the messages without breaks. If you now quit the Serendipity Client and relaunch it the session will be saved and then restored with all the configuring in tact.

Serendipity Blackmagic Server

Overview

The server runs on the main machine where the dongle is installed. This handles the processing of all jobs through the system and must be started before the Client is launched.

As the Server starts it checks to make sure a valid dongle is installed on the machine and checks which modules are enabled (licensed). It calculates the speed of the machine that it is running on and checks the integrity of the database before loading it. Once the server is up and running a clock keeps a track of the duration that the server has been running for. The options available for the server are shown below.

Server options

Once the server is running the window below displays the server information and various options.

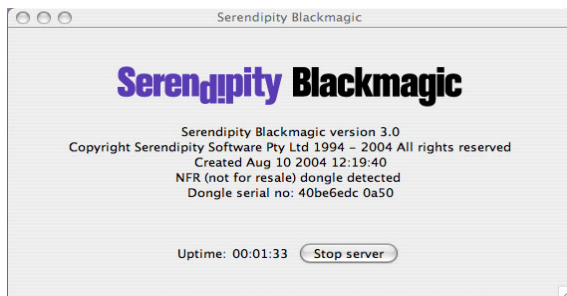

Startup Options

- Start server on launch - When this option is ticked the server will start once the application is launched.
- Restart server after crash - This option restarts the server after a crash.
- Start as slave - This allows you to run the server as slave device. See “Cluster Manager” on page 102 for more information.
- Start in safe mode - This starts the server but does not process any jobs or poll any rips. This is a maintenance mode that allows you to manage configurations if they become corrupt or configured incorrectly. Once maintenance is complete the server must be restarted again in normal mode.

File menu

- Stop server - Stops the server from running without quitting Serendipity Blackmagic.
- Start server - Starts the server if it is in a stopped state.
- Restart server - restarts the server.
- Close - Close the window. If the Server is running you are warned and asked to confirm Server shutdown.
- About - Shows information about the server. Clicking more/less info shows or hides valid dongle options including the versions of the current drivers.
- Quit - Does the same as close.

The Serendipity Client

Overview

The Serendipity Client is a Graphical User Interface which is used for configuration, maintenance and monitoring of the Serendipity Blackmagic server. The Client can be installed and run locally on the same machine or from any supported computer on the network using TCP/IP protocol. There is no limit to the number of clients that can be connected to the server. Each Client will have its own settings specific to the user.

Once installed the Client connects to a Serendipity Blackmagic server and loads the settings from the server into the Client interface. Any Client can access all of the job management and view the current status. The configuration can be open to all users or protected with a password which would prevent changes.

Look and Feel

The look and feel of the client follows a common theme and functionality. Any list can be ordered by selecting the title bars at the top of it. They can also be resized by clicking and dragging the dividers between titles. Anywhere there is a chooser to select an item from the database there is a search field indicated by a magnifying glass. Entering text in here filters the list showing only the items that match. There are also many ways to complete the same task such as configuring a Pagesetup from the QueueManager. Many options available using the right mouse click to bring up other menus. This will vary depending on the section of the interface where the mouse is.

There are three main sections to the client. The Workbench is used to configure the various parts of the server. This is used to create queues, set up input paths and various calibration functions. The Monitor is used for managing and viewing jobs as they pass through the system. Then there are the Applications that add functionality and provide tools for managing the server. There are also various menu options that have system utilities and system preferences.

Workbench

This is where the main configuration takes place. You can set up RIP inputs, Pagesetups, output paths, colour sets and curves. When items are created or changed in the Workbench they are saved to a database. This database is read by the server each time at start up. It can be backed up and copy to other servers.

The Workbench has a split window. One side shows data types (which are database groups) and allows you to select items from the database, and the other displays the items information allowing you to make changes. The split window can be moved by selecting it and dragging it to resize as desired. You can also change the split view between horizontal or vertical depending on your preference by selecting the View option from the menu. The Data types section has two views. Browse allows you view and select any of the database items to display them. Clicking the tab with the magnifying glass flips to a search window allowing you to find any item that matches a search text entered.

The view of the Workbench will vary depending on the items selected. Simple items such as DotGain Curves are single items without references. The view allows you to create or adjust a single item and save it. Other items such as Pagesetups are more complicated with multiple configuration panels and multiple references. References are other items in the database that have been selected and saved with another item. When you select a Pagesetup for example there may be a reference of a Gradation Curve. These references can be selected and configured as needed or hidden from view.

With items that have more than one configuration module such as Pagesetups, they are split into logical areas. Each panel can be colour coded or hidden by clicking the cross (x) in the upper right of the box. This does not disable the panel items but hides it from view to make them simpler. You can hide items that are not being used for example. If you want to bring the panel back again right click and select Jump To Selection and choose the panel to jump to. The ones in brackets () are hidden. Items that you can choose in the Pagesetup such as a Curve or Paper Profile are references. These can be edited directly or new ones created, selected and saved with the Pagesetup.

Menu Items

- File
 - New - Create a New Item in the database.
 - Save - Save changes to the database.
 - Duplicate - Make a copy of the currently selected Item.
 - Revert - Reload the last saved version of the currently selected item.
 - Delete - Delete the currently selected item.
 - Show Referrers - Shows what items are using the selected reference. e.g. the names

of the Pagesetups that are using a particular curve.



TIP

You can search for items and then edit them directly. Select an item from the list and then select the “Edit” button. This will close the Referrers window and open the item selected in the Workbench ready for editing. If you double click the item it is selected in the Workbench for editing and the referrers window is left open allowing you to select other items to edit.

- Show Orphans - Shows any item that is currently in the database but not being used by a pagesetup or RIP.

Usage: This is used for cleaning up a database and deleting items no longer used. Selecting it will search through the database and then display all items that are considered orphans. You can select an orpahn, view it configuration and choose to delete if needed. This way you know that you are not deleting items that are in use.

- Edit
 - Undo - Undoes the last change. There are multiple undo's and this is configured in the System Settings.
 - Redo - Redoes the last undone change. There are multiple redo's depending on the undo status and setting in the System Settings.
- View
 - Split Vertical - changes the view so that the Data types and Items are displayed across the top of the window and the selected item is displayed across the bottom.
 - Split Horizontal - Changes the view so that the Data types and items are displayed on the left of the window and the item selected is displayed on the right.
 - Show references - Shows or Hides the References from the lists.
- Window
 - This shows any window of the Client that is open and it can be selected to bring it to the front.
- Help
 - What's This - Select this and then click on any part of the interface to get a short help.

Monitor

The Monitor displays jobs before, during and after processing. It allows you to manage jobs through the system, plot their progress and give you feed back from the server and client via logs. You can add modules and configure the look to suit your requirements. A Monitor consists of one or more Tabs. Each tab can be named as desired and a background colour or image selected to personalise it. Modules are added, positioned and sized according to your requirements. The settings are saved per user so each user can create their own preferred view. You can also save your Monitor setup or load a pre-configured one.

The Monitor can be in one of two modes, Edit or Use which can be selected through the Layout menu or by right clicking on the Monitor background.

Edit

This mode allows you to move and resize modules on a Tab. The mouse pointer changes to a cross. You can resize a module by grabbing the corners or sides and dragging to your preferred size. Click anywhere in the modules and drag it to the desired position. As you move modules close to each other they will snap to each other.

Use

This is the normal user mode. It locks the module sizes and position and allows you to configure the modules preferences and manage jobs.

Menu Items

- Layout
 - Edit - Switches the Monitor to Edit mode.
 - Use - Switches the Monitor to Use mode
 - Dynamic Update - Enables or disables updates to the modules while in Edit mode.
 - Show Titlebars - Shows or hides a title bar at the top of every module. e.g. QueueManager is displayed above the appropriate window.
 - Add - Modules - This adds the various available modules to the Tab. See “Monitor Modules” on page 30 for more information on each one.
 - Load - Loads a previously saved Monitor configuration.
 - Save As - Saves the current Monitor configuration.

- Tabs
 - New Tab - Creates a new Tab.
 - Rename Tab - Renames the currently selected Tab.
 - Duplicate Tab - Duplicates the current tab and all modules in it.
 - Choose Tab Colour - Allows you to select a colour for the currently selected Tab.
 - Choose Tab Image - Allows you to select an Image for the currently selected Tab. Valid file types are PNG and JPEG.



It is recommended that you do not use a large image as this takes up memory.

- Clear Tab Colour - Reverts to the default colour.
- Clear Tab Image - Reverts to the default colour.
- Remove Tab - Deletes the currently selected Tab.
- Remove All Tabs - Deletes all Tabs.

Re-ordering Tabs

You can re-order tabs by selecting a tab with the mouse and dragging it into a new position. A red triangle appears showing the drop point between two tabs.

Monitor

Name	Size	Date	Path
DSC00547	1.37MB	19/04/02 1:56 PM	
DSC00548	1.29MB	19/04/02 1:56 PM	
DSC00549	1.41MB	19/04/02 2:01 PM	
DSC00550	1.38MB	19/04/02 2:01 PM	
DSC00551	1.23MB	19/04/02 2:02 PM	
DSC00552	1.33MB	19/04/02 2:03 PM	
DSC00553	1.25MB	19/04/02 2:05 PM	
DSC00554	1.37MB	19/04/02 2:06 PM	
DSC00555	1.24MB	19/04/02 2:11 PM	
DSC00556	1.05MB	19/04/02 2:12 PM	
DSC00557	1.17MB	19/04/02 2:13 PM	
DSC00558	1.13MB	19/04/02 2:13 PM	
DSC00559	1.25MB	19/04/02 2:16 PM	
DSC00560	1.25MB	19/04/02 2:16 PM	
DSC00561	1.15MB	19/04/02 2:17 PM	
DSC00562	1.31MB	19/04/02 2:40 PM	
DSC00563	1.17MB	19/04/02 3:00 PM	
DSC00564	1.25MB	19/04/02 3:21 PM	
DSC00565	1.33MB	19/04/02 3:23 PM	
mill-maize	397.64KB	13/02/04 11:22 AM	
tree	359.67KB	13/02/04 11:12 AM	
tree-cmyk	2.70MB	7/06/04 4:01 PM	
tree2	390.14KB	13/02/04 11:12 AM	

Monitor Modules

Overview

Modules are used for monitoring and managing jobs through the system. They can be added to a Monitor Tab as part of a Monitor layout or selected as a Floating Module where the window is standalone. Modules are added to a Monitor through the Layout menu (the Monitor must be selected). Floating Modules are available from the Applications menu. The available modules are detailed below.

RIPMonitor

This displays the RIPs that have been configured under the RIP section of the Workbench. Jobs that have been successfully polled are displayed showing any plates that are associated with them. These jobs can be submitted to a Pagesetup for processing. The RIPMonitors view can be customised as desired. There are many options available with the RIPMonitor, many of which are available as a context menu (right click). The context menu changes depending on the area you are in when you click. The various options available for the RIPMonitor are described below.

The View

- **Jobs** - This is the large window to the right and displays all successfully polled jobs from the selected RIP.
- **RIP List** - This is a list of all the RIPs that are configured allowing you to select each in turn to display the jobs on that RIP. This is shown on the left side of the window and can be shown or hidden as desired.
- **RIP Menu** - This is a pull down list shown at the top of the window of RIPs configured and shows the current selection. This can be shown or hidden as desired.

 Hiding this will also hide the Polling ON/OFF pull down selector. You can turn the Polling on or off from the right mouse button or by selecting the Toggle Polling check box next to the Poll button on the toolbar.

Usage - If you only have one RIP configured then it is better to hide the left RIP list and Top RIP Menu as there is nothing else to display and it gives you more space to view your jobs.

Context menus

- **Poll** - Initiates a manual poll of the selected RIP.
- **Toggle RIP polling** - Turns the polling on or off. When the RIP is in the off state the name in the RIP list turns red.



The RIP jobs list is cached and sometimes requires clearing. To do this turn the RIP off and then on again. Then poll the RIP three times.

- **Show RIP Menu** - Shows or hides the RIP pull down list at the top of the window.
- **Show RIP list** - Shows or hides the RIP list on the left.
- **Edit RIP** - This gives you the ability to edit the RIP selected. You can choose to edit a single section or all sections of the configuration. Alternatively you can create a New RIP.
- **Colour Scheme** - Choose a colour for the module.
- **Font Options** - Choose the preferred font size.
- **Language Encoding** - Choose the language encoding for your operating system. This allows jobs to display correctly in the RIP-Monitor in the native language.

Context Menu options available for jobs.

These options are only available if a job is selected and are additional to the ones above. They are also available from the Toolbar. They are as follows.

- **Expand Jobs** - Shows the plates associated with the selected jobs.
- **Collapse Jobs** - Hides the plates associated with the selected jobs.
- **Submit** - Submits the selected jobs for processing. Selecting this brings up a chooser for you to select one of more Pagesetups to send the files to.
- **Submit for De-imposition** - Submits the selected jobs for de-imposition.

- Virtual Press - Adds the selected jobs to the Virtual Press. See Virtual Press on page 31.
- Group By Job - Keeps the plates in their respective job group when they are copied into the Virtual Press.

Effects - When you have multiple jobs selected to be copied into the Virtual Press, with this option ticked they are kept as their respective jobs. If you have the option disabled then all the jobs and plates selected are copied into as one job. This is useful if you are polling a RIP and the plates are shown as separate jobs with one plate each.

Buttons

- Poll - Initiates a manual poll of the selected RIP.
- Submit - Submits the selected jobs for processing.
 - Hold after imaging - Places the job on hold in the Rendering queue. i.e. after imaging has completed successfully. This option is available in the submit window.
- Virtual Press - Adds the selected jobs to the Virtual Press.
- Group By Job - When adding more than one job to Virtual Press with Group By Job option enabled the jobs are added to the history i.e. as separate jobs. If the option is disabled then the jobs are added as a single job i.e. all plates merged.

Usage - Disable the Group By Job option when the plates are displayed as separate jobs and you wish to submit them as a single job merged.

- Show - This option is available when the RIP selected is a supported Imposition RIP. i.e. Fuji Celebra or Scitex Brisque. the options available are
 - All Jobs - Show both page and imposed jobs.
 - Impose Jobs - Show only imposed jobs.
 - Page Jobs - Show only single page jobs.
- Search - Search for jobs. Entering text will show only jobs that match. This matches any characters displayed in the jobs section.



TIP You can enter some text that would only show certain jobs. If you have jobs that have a common name or size you can have a RIPMonitor dedicated to viewing these jobs and enter the text that is common in the search field to display only those jobs.

Virtual Press

Virtual Press gives you the ability to manage the plates of the job. You can drop plates, change plate colours and merge plates from other jobs. If a job contains an un-allocated plate i.e. no colour, then you need to use the Virtual Press to allocate a colour for it (unless a replace colour set is selected that contains the plate.) The available options for Virtual Press are shown below.

History Options

The history keeps jobs that have been imported into Virtual Press. Any changes or additions are kept so the jobs can be re-submitted at any time without having to recreate the changes again. The history is held while the Client is running. Once the Client is quit the history is purged.

- Show History - This shows or hides the history window on the left.
- Arrows - Use the arrows to move up or down the jobs in the history window.
- Preferences - There are a couple of preferences available for the history which give you options after a successful submit. These are
 - Goto Next History - Moves to the next job in the list of the history after submit.
 - Delete Current History - Deletes the job from the history list after submit. This is only available if Goto Next History is enabled.
 - Dismiss VirtualPress - If enabled the VirtualPress will automatically dismiss after the job has been submitted.
 - On Last History - This is used by the Dismiss VirtualPress option so it will dismiss after the last job in the history column has been submitted. Otherwise the VirtualPress will dismiss after each job.
- New - Create a new job in the history. This is an empty job so that plates can be dragged in from the RIP list to create a new job.
- Rename - Rename the selected job. Selecting the job name and hovering over it a short while

will also enter edit mode allowing you to change the name.

- Delete All - Removes all jobs from the history list.
- Delete - Removes the currently selected job from the history list.
- Submit For Deimposition - Submits the currently selected job for de-imposition.
- Quick Submit - Shows a pull down list of the configured Pagesetups. The Quick Submit button submits the currently selected job to the Pagesetup shown.
- Choose - Allows you to choose a colour from the colour libraries. This is only available for special plates. You can also double click the plate in the list to choose a colour from the libraries.
- Revert - Reverts a colour back to its original state.
- Submit - Submits the currently selected job for processing. This displays a chooser allowing you to select one or more Pagesetups to send the job to.
 - Hold after imaging - Places the job on hold in the Rendering queue. i.e. after imaging has completed successfully. This option is available in the submit window.
- Clear - Removes the selected plates from the job.
- Clear All - Removes all plates from the job.
- Dismiss - Closes the Virtual Press window.

 **HowTo** You can re-order the plates in a job by selecting the plate in the list and dragging it to a new position. The order of the list dictates the order that plates are merged and can affect the job where plates have attributes like Opacity.

- Tint - Adjust the tint value of the special plate.

 **HowTo** Adjust the tint value of a special colour

You can adjust the Tint value or intensity of any special colour. This can be done by editing the Special Colour Set for a permanent change. Or to make an

adjustment for a single instance simply double click on the tint value in the Virtual Press and enter a new value. This is stored in the history with the job but the colour in the library is not affected.

QueueManager

The QueueManager views the jobs in the system after they have been submitted. You can view one or more queues simultaneously, showing the jobs progress through the system. From the QueueManager you can manipulate your job in a number of ways such as holding, promoting and deleting. The various options available are shown below.

View Options

You can view a lot of information about each job as it passes through the system. You can choose the properties of a job you wish to view by selecting which columns to show and which to hide. This is achieved by right clicking in the column header bar and choosing the properties you want to display. The columns can be re-arranged in the order that you prefer by selecting the title and dragging it along the bar to the desired position. The options available are shown in table 1

Table 1:

Property	Description
Name	Job name
Process Time	Time taken to process the job
Status	The Jobs current status
Source	Where the job was submitted from.
Date	The Date and time the job was processed.
Pagesetup	The Pagesetup the job was processed on.
Queue	The Output queue the job was processed to.
Size	The size of the job. (Disk space used)
Width	The width of the job
Height	The Height of the job.

Table 1:

Property	Description
DPI	The imaged resolution of the job.
Output Colour Space	The Colourspace of the output file.
Copies	The number of copies of the job
Screening	The screening applied to the job
Thumbnail	Show a thumbnail of the jobs.
JobID	The ID of the job
Node	The server or slave that the job was processed on
Signature Group	The Signature Group used to de-impose the job.
Signature	The Signature of the group used to de-impose the job
Page	The Page number of the job
Publication	The publication name

Actions

There are a number of actions that can be performed on a job. These are available as a context menu (right click) or by opening the tool bar (clicking the spanner) at the top of the QueueManager. You can choose which actions to show on the Tool bar by right clicking and turning them on or off as desired. You can also select the "Configure Toolbar" option which displays a chooser. On the left are the toolbar items that are available and on the right the items that are showing. You can move items between lists in a number of ways. Either selecting the item and clicking the arrow in between the list, double clicking the item or dragging the selected items between the two lists. You can then choose the order that they are displayed by moving items around in the "showing" list. Options become available when one or more jobs are selected. Only valid actions for the job status are shown. e.g. The action to "Nest Now" is only available when the job has a status of "waiting to nest". The options are

- Pause/Resume Printing - Pauses/releases the current queue. Jobs waiting in a paused queue are displayed in Red.
- Submit - Submits the selected jobs to the printer. Available when the status is "Done"
- Job Info - Gets information about the currently select job. The job info contains all details of how the job was processed and displays a thumbnail preview of the job and the configuration etc. You can print the Job Info by right clicking on the Job Info window and selecting Print. This will choose a system printer.



TIP

You can also get the JobInfo and thumbnail by double clicking on the job. If you have multiple jobs selected then the job info window will display information about all of them. As this can be quite wide you can scroll horizontally by holding the shift key and using the mouse wheel. If you hold you the control key (windows) or apple key (macs) and scroll with the mouse wheel then the font size will change.

- Modify - Allows you to modify various attributes of the job. These are
 - Name - Change the name of the job.
 - Publication Name - Change or add a publication name.
 - Page number - Change the page number of the job.
 - Copies - Change the number of copies of a job.
 - De-Imposition - Change or assign a Signature group and signature to a job.
- Cancel - Cancels the currently processing jobs.
- Delete - Deletes the currently selected jobs.
- Hold - Holds the currently selected job. Available when the status is "waiting".
- Release - Releases a currently selected held job.
- Retry - Retries a job that has failed.
- Queue Order - Allows you to configure which queues are viewed by the QueueManager. Selecting this presents you with a chooser window showing two lists. The "Available" queues on the left and the "Showing" queues on the right. To move queues between lists you can either select one or more entry and drag

from one list to another. Alternatively you can double click an entry to move it to the other list. The order of the queues in the “Showing” list determines the order of the queues when they are sorted by any column apart from Queue. (When Queue is selected as the sorted column then they are sorted in alphabetical order.) Queues are sorted by clicking on the title bar.

- View Imaged - Views the imaged file in the Soft Proof application of currently selected jobs.
- View Rendered - Views the rendered file in the Soft Proof application of currently selected jobs.
- Render again - Submits the currently selected jobs to the rendering queue for processing. Available when the status is “Done”.
- Nest Jobs - Submits the currently selected jobs to be nested. This sends the job to the rendering queue to re-render for a nest. The Collating section of the output is used for the nesting parameters.
- Nest Now - Nests any job waiting to nest. This is available when the selected job has a status of “waiting to Nest”. Only one job needs to be selected and all jobs that have the waiting to nest state will be nested.
- Duplex Now - Duplexes any job that has a state of “waiting to duplex”. Only one job with that state needs to be selected for all job to be duplexed.
- View Errors - Views the errors of the selected job if the status is “Failed”.
- Rush Jobs - Moves the currently selected jobs to the top of the current Queue for processing next. The status must be “waiting”. Jobs that are currently being processed are completed first.



This moves the jobs up the current queue only. Therefore if the job is in the Imaging Queue and Rush Jobs is selected the job moves to the top of the Imaging Queue. Once completed it will move to the bottom of the Rendering Queue.

- Move To Pagesetup - Moves the currently selected jobs to another Pagesetup. This will send the jobs to the rendering queue again with

the attributes of the selected Pagesetup. You can view the Pagesetup, edit it or create a new one prior to submitting the job.

- Copy to Pagesetup - Copies the selected jobs to another pagesetup. This will send the jobs to the rendering queue again with the attributes of the selected Pagesetup. You can view the Pagesetup, edit it or create a new one prior to submitting the job.
- Show - You can show certain jobs in the QueueManager. You can select any or all of the options to filter the jobs. Choose between
 - Active - Jobs that are currently processing.
 - Waiting - Jobs that have a state of Waiting.
 - Done - Jobs that have completed.
- Search - Find jobs that are in the queue. Enter the text to search and all jobs that match the text are displayed. All elements of the job are searched, not just the name. This can act as a filter.



You can enter some text that would only show certain jobs. If you have jobs that have a common name or size you can have a QueueManager dedicated to viewing these jobs and enter the text that is common in the search field to display only those jobs.

- Refresh Queues - Updates the Queues.

Configure - There are a number of configuration options available from the context menu. These are shown below

- Queue Colour - Allows you to select a colour for the queue. The Queue colour of the selected job changes. This colour is carried through to the Queue Status window.
- Queue Order - Allows you to configure which Queues are viewed and their order. See Queue Order earlier on page 33..
- Print Gallery Mode - This displays the jobs in the QueueManager with a thumbnail, name, queue and status. You can change the size of the thumbnail from small, medium and large by selecting Apple + to increase size or apple - to decrease size. (control + and control - on windows)
- Show Idle Queues - Display Queues even if there are no jobs in them. Without this selected only jobs are displayed. This is only valid if

more than one queue is showing per QueueManager.

- **Group By Queue** - Groups the queues together when sorting. i.e. if you are sorting by job name then the QueueManager is sorted alphabetically per queue. If it is not enabled then the whole name list is sorted alphabetically ignoring the queues. This is only valid when more than one queue is showing per QueueManager.
- **List Colour** - Allows you to pick a colour for the whole QueueManager list.

Usage - Select a colour for the list and turn off “Group by Queue”. This will display alternating lines of colour in the list making it easier to see jobs and their attributes.

- **Colour Scheme** - Allows you to pick a colour for the QueueManager window.
- **Font Options** - You can change the font size of the QueueManager and the jobs displayed.
- **Edit Output** - Allows you to edit the output of the currently selected job. If no job is selected then you can only make a new one.



This edits the output and not the job. For the changes to be effective you would need to submit the job again for printing or rendering depending on the attribute changed.

- **Edit Pagesetup** - Allows you to edit the Pagesetup of the currently selected job. If no job is selected then you can only make a new one.



This edits the Pagesetup that the job was processed with. For the changes to effect the currently selected job you may need to re-render or re-image the job depending on the attribute changed.

- **Edit RIP** - Allows you to edit the RIP of the currently selected job. If no job is selected then you can only make a new one.



This edits the RIP of the source file i.e. where the job was submitted from (if it was a configured RIP). The job would need to be re-submitted again or the polling refreshed for the changes to take place.

- **Edit Signature Group** - Allows you to edit the Signature Group of the currently selected job. If no job is selected that has been submitted

through the deimposition module then you can only make a new one.



This edits the Signature Group that was used for de-imposing that job. For the changes to effect the currently selected job it would need to be re-submitted for de-imposition again.



When you are editing any of the items from here you are editing the queue for all future jobs, not just altering the queue for that job.

- **Export** - Allows you to export elements of the job. The options are

- **CIP3 (Version 3.0)** - Exports job information to a file in CIP3 format - Version 3.0.
- **CIP3 (Version 2.1)** - Exports job information to a file in CIP3 format - Version 2.1
- **Postscript (separated)** - Exports the current job as a separated PS file.
- **Tiff Multichannel** - Exports the current file as a multichannel Tiff.



TIP

The CIP3 export options allow you to choose the orientation before you export it. You can select orientation of 90, 180 and 270 degrees.

Queue Status

This module is a progress meter that shows current status of jobs active on the selected queue. You can change the look of the Queue Status and the Queue it is monitoring. The options are available by right clicking on the window and are detailed below.

- **Cancel Job** - Cancels the currently active job. This is only available when a job is active.
- **Job Info** - Gets info about the currently active job. This is only available when a job is active.
- **Pause Processing** - Pauses the Queue so no further jobs will process. Any job currently active in the queue will finish. The text in the window changes to red showing it to be in a paused state.
- **Resume Processing** - Takes a queue out of a paused state so that jobs waiting to process through that queue can resume.
- **Change Queue** - Allows you to choose which queue the status window will show.
- **Edit Output** - Allows you to edit the output or create a new one. You can only edit if the queue is showing an output. i.e. if the queue is

set to Spooling, Auto detect, Imaging or Rendering then you can only make a new output.

- Font Options - Allows you to change the size of the text.
- Queue Order - Select which queues you wish to view. Selecting this presents you with a chooser window showing two lists. The “Available” queues on the left and the “Showing” queues on the right. To move queues between lists you can either select one or more entries and drag from one list to another. Alternatively you can double click an entry to move it to the other list. The order of the queues in the “Showing” list determines the order of display.
- increase/decrease indent - Increases or decreases the size of the queue status in view.



TIP

Double clicking in the Queue Status window displays a floating QueueManager window showing that queue. This has the full functionality of the standard QueueManager.

Thumbnail

This displays a thumbnail of jobs as they are imaging and rendering. The Thumbnail is updated with the progress at the same time as the imaging or rendering queue status is updated. There are a couple of options available from the contextual menu (right click) as follows.

- Show Imaging - Show the imaging thumbnail.
- Show Rendering - Show the rendering thumbnail.
- Normal thumbnail - Displays a small thumbnail.
- Large thumbnail - Displays a large thumbnail.



TIP

This means that you can display two thumbnail windows and configure one to be the imaging thumbnail and one to the rendering thumbnail.

DropZone

A DropZone is a place where you can drag and drop files for processing. You select Pagesetups or Pagesetup pools to add to the DropZone. These DropZones take the same file formats as the drop folder. See DropFolders on page 58 for more information. The available options are

- Add DropSpot (Pagesetup) - Select one or more Pagesetups to add to the DropZone. Selecting this displays a chooser window showing all available Pagesetups.
- Add DropSpot (Pagesetup Pool) - Select one or more Pagesetup Pools to add to the DropZone. Selecting this displays a chooser window showing all available Pagesetup Pools.
- Remove DropSpot - Remove the selected DropSpot. This option is only available when right clicking over a DropSpot.
- Edit Pagesetup - Allows you to edit a section of the selected pagesetup, all sections or create a new one.
- Increase DropSpot Inset + - Increases the size of the DropSpot.
- Decrease DropSpot Inset - - Decreases the size of the DropSpot.
- Font Options - Allows you to change the size of the text.

Status

Shows the current disk status (usage) of the server processing areas such as spooling, temporary directories and DropFolders. You can change these disk locations by editing the etc./ss.conf file in the installation directory. See.... The options available are

- Update - Checks the disks and updates the view.
- Preferences - Sets the Status window preferences. Available items are
 - Update interval - Sets the time between updates.
- Colour Scheme - Changes the colour of the Status window.
- Font Options - Allows you to change the size of the text.

ClientLog

The ClientLog displays any messages that pop up during normal Client operation. There are different levels of message from informative to serious errors. All messages are held for a user determined length of time. There

are various options available with the ClientLog which are shown below.

- Fetch back log - Displays the log for the time specified e.g. retrieves and displays the last 4 hours of messages. Choose the time from the pull down list.
- Trim older lines - Trims the log based on the time selected in Fetch back log. i.e. if this is set to 60 minutes then the log file is trimmed back so that only the last 60 minutes remain.
- Export - Allows you to export the log to a file.



HowTo

When you export the log file you can choose to export everything that is in view or select entries to export. Use the filtering options and fetch back log choice to limit the view before exporting. Selecting Export displays a chooser allowing you to enter a name and select a location to save the file. You can also choose to save the file as a html or tab delimited text file.

Filtering options

You can choose which message to display in the log and which ones to hide by selecting one of more of the following filter. All messages are still saved to the log.

- Question - Used for messages that ask questions e.g. “Job contains unassigned colours. Do you want to add them to Virtual Press”
- Information - Used for messages that tell you something. e.g. “Job has a duplicate plate”.
- Warning - Used where the message is more important. Usually the Client failed to do something but operation can still continue. e.g. “Failed to save new password. Old one will continue to be used.”
- Critical - Used for serious errors that will most likely effect operation. e.g. “Failed to load rendering dll”. You will normally need to take action to rectify this before continuing.
- Search - You can search the log for jobs or messages. Enter the text of characters that you want search and the ServerLog only displays the lines that match the search.

Display Options

You can choose part of the message to show by selecting the columns to display and those to hide. By right clicking over the column headers and you can turn the columns on or off. You can also change the

order of the columns by selecting the column headers and dragging them to the desired position. The available options are

- Type - The level of the message reported. i.e. Question, information, warning or critical.
- Date - The time that the message was reported.
- Source - This is the Module or Application that reported the message. e.g. Soft Proof
- Summary - A summary of the message that was reported.
- Command - Internal command that is used to communicate messages to and from the server by the Client.
- Error - An error code reported by the server. This is useful for debugging problems.
- Action - The Action that was taken by the user in response to the message. i.e. the button that was pressed when the message popped up.

ServerLog

The Server log shows messages from the server. The options are

- Fetch back log - Displays the log for the time specified e.g. retrieves and displays the last 4 hours of messages. Choose the time from the pull down list.
- Trim older lines - Trims the log based on the time selected in Fetch back log. i.e. if this is set to 60 minutes then the log files is trimmed back so that only the last 60 minutes remain.
- Export - Allows you to export the log to a file. Selecting this displays a dialogue window with various options as shown below.
 - Destination File - Choose the filename and location where the file is to be saved. Use the Browse button to navigate to your preferred location.
 - Message Lines - Choose to save all messages in the log window or only those that are highlighted. This way you can save just a couple of lines if desired.
 - Format - Choose the format to save the file in either html or plain text. The plain text file is saved with tabs characters between the columns.

- Cancel - Revert back to the server window without saving anything.
- Save - Save the file based on the settings selected.
- Configure Filter - You can filter messages in the log. Choose between the following
 - Completed Jobs - Show messages about completed jobs.
 - Polled jobs - Show messages about polled jobs.
 - Errors - Show errors from the server.
- Search - You can search the log for messages. Enter the text of characters that you want search and the ServerLog only displays the lines that match the search.

Display Options

You can choose the parts of the message to show by selecting which columns to display and which to hide. Right click over the column headers and you can turn the headers on or off. You can also change the order of the columns by selecting the column headers and dragging them to the desired position. The available options are

- Module - This is the function that the server used.
- Routine - This is the operation inside the function.
- Date - The time that the server called the module.
- Message - The message that resulted from the routine.

Cluster Status

This is a monitor that allows you to see the current status of any masters or slaves that are running. The options are

- Refresh - Update the status.
- Increase Inset + - Increases the gap between the list items.
- Decrease Inset - - Reduces the gap between the list items.
- Font Options - Allows you to change the size of the text.

Workbench

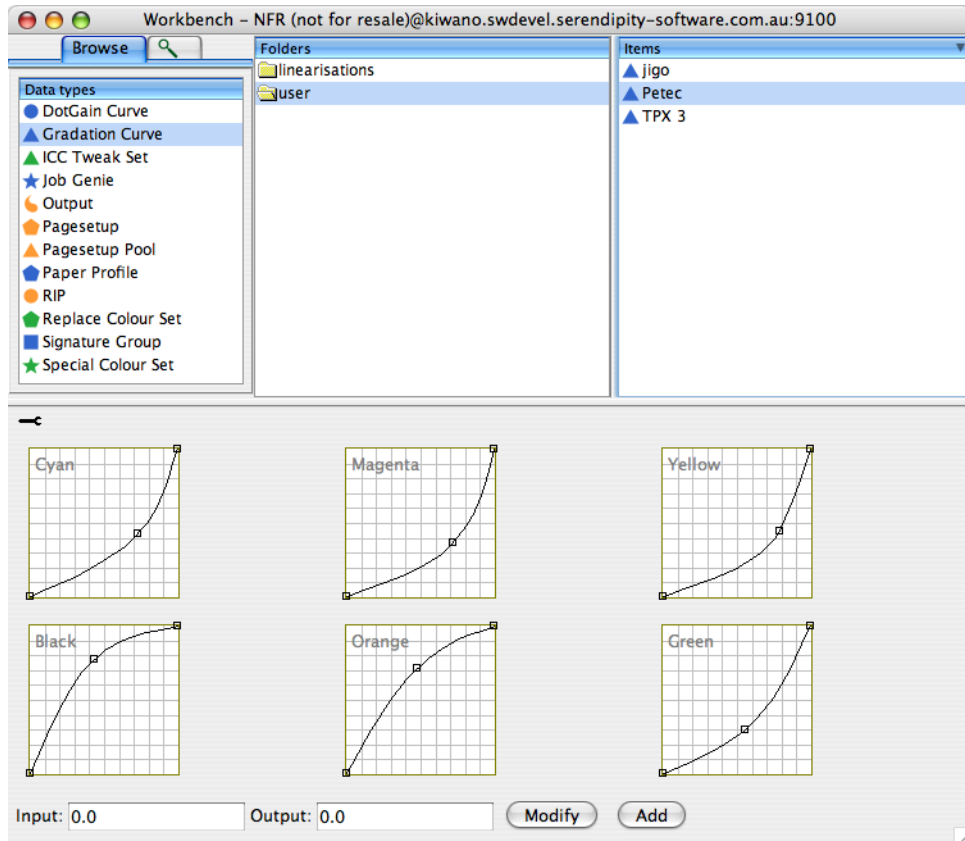

Dot Gain

Overview

A DotGain curve can be used to compensate for or represent dot gain on the final output. You can create and apply a DotGain curve to a Pagesetup to change the output. This may be applied for two reasons. Firstly, after initial calibration you may find that the resultant output is either slightly too dark or slightly too light. A dot gain curve can be applied to the process or specials (or both) to make the print lighter or darker accordingly. The other place that a DotGain curve would be applied is to represent a presses or printing process dot gain on the proof. This in particular is used in Flexographic workflows to better represent the final output on the proof. The available options are as follows.

- Show/Hide Original curve - A green line appears showing where the curve was last saved. This allows you to see where you have edited the curve from.
- Increase Margin - You can increase the margin around the graph area.
- Decrease Margin - You can decrease the margin around the graph area.

Usage - You would need to increase the margin if the handle (end point) from the bezier curve adjustment is outside of the viewable area (window pane). By increasing the margin you are able to see and move the handles. Use the decrease margin option to enlarge the graph area again.

- Dotgain Table - This allows you to enter values manually to adjust or create a curve.

Usage: Select the first value field and enter the value that was read e.g. if you read 7% at the 5% mark you enter 7 in the field. Press the Enter key to enter the value and move to the next value in the column. Once completed close the table and save the curve.



HowTo

1. Create a new curve. This is created as untitled. Select "untitled" and enter the name that you wish to call the curve.
2. Left click on any point of the curve and drag it to the desired position. The curve produced is a bez-

ier curve which has handles on each end of a line allowing you to manipulate the curve smoothly.

3. Grab one of the handles with the left mouse button to change the curve without moving the fixed position or anchor.
4. Select another part of the curve with the left mouse button and drag to another position.
5. To remove the points, select the anchor point and press the delete key.
6. Save the curve once completed.



TIP

If the print is too dark then create and apply a curve with a slight dip (pic 1) - If the print is too light then create and apply a curve with a slight arch. (pic 2)

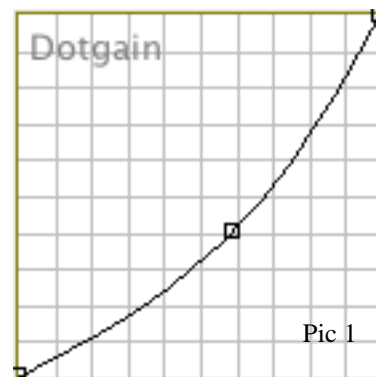

Pic 1

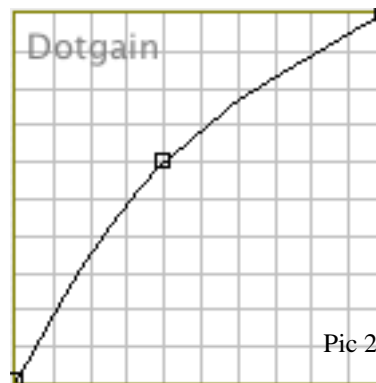

Pic 2

Gradation Curve

Overview

A Gradation Curve is used to adjust colour in a job by applying a curve to the process colours individually. There are six process curves available, CMYKOG. The Gradation Curve can be applied to a Pagesetup in two places. Either as a Linearisation curve or as a Correction Curve. A linearisation curve is normally applied as part of the early calibration stage and this is recommended. See the “Calibration Guide” on page 118 for a more detail. A Correction curve is normally applied if a small amount of fine tuning is required after normal calibration procedures. The available options for the curves are as follows.

Curve View Options

There are four view options available.

- **Single** - This views each curve in a separate tab. The other curves are available by selecting the relevant tab at the bottom of the window.
- **Six: 3 x 2** - This views all the curves on a single screen in a 3 x 2 matrix i.e. two rows of three curves.
- **Six: 2 x 3** - This views all the curves on a single screen in a 2 x 3 matrix i.e. two columns of three curves in each column.
- **Four: CMYK, Two: OG** - This views the four process curves together with the other two (Orange and Green) available by selecting the tab at the bottom of the screen.
- **Show/Hide Original curve** - A green line appears showing where the curve was last saved. This allows you to see where you have edited the curve from.
- **Increase Margin** - You can increase the margin around the graph area.
- **Decrease Margin** - You can decrease the margin around the graph area.

Usage - You would need to increase the margin if the handle (end point) from the bezier curve adjustment is outside of the viewable area (window pane). By increasing the margin you are able to see and move the handles. Use the decrease margin option to enlarge the graph area again.

- **Gradation Table** - This allows you to enter values manually to adjust or create a curve.

Usage: Select the first value field and enter the value that was read e.g. if you read 7% at the 5% mark you enter 7 in the field for the respective colour. Press the Enter key to enter the value and move to the next value in the column i.e. on the same colour. Once completed close the table and save the curve.

- **Preview Curves** - Displays a window of all the curves in their respective colours so that you can assess them in relation to each other. This is updated dynamically as changes are made.
- **Tool Bar** - Click the spanner to show or hide the tool bar. Right click in the tool bar area to show/hide the Curve view options.



HowTo



1. For a correction curve select the user folder and create a new curve. This creates an Untitled curve
2. Select “Untitled” and enter the desired name.
3. Choose the preferred curve View Option.
4. Select a point in the curve that you wish to adjust with the left mouse button and drag the curve to the position desired. This produces a bezier curve.
5. The curve can be adjusted by selecting either handle (end points) of the Bezier curve and moving or extending them.
6. Select another point on the curve to adjust in the same way as desired.
7. To remove points, select the anchor points and press the delete key.
8. Repeat for all the process colours as required.
9. Save the curve once complete.
10. The curve is then available for selection in the Pagesetup.

ICC Tweak Set

Overview

This module allows you to build up a library of colours that need “tweaking” (adjusting) for accurate output. A Tweak Set alters colours during the ICC mapping stage from input to output profile and is selected on a per Pagesetup basis. The ICC profiles are not edited in any way and the Tweak Set can be selected as desired. Each colour that requires alteration is selected and then adjusted by adding or subtracting process colours from it, or making it lighter or darker. An accurate visual representation is shown on the screen and the point in the colour space can also be viewed. Colours can be created manually by entering the CMYK or LAB values or input automatically using an on-line spectrophotometer. The interface is split into two parts. The left side shows the input values and the right side is the place where adjustments are made or the tweaked side. The available options are as follows.

Options

- Colourspace - Choose between Input Profile or LAB input. i.e. the values used to create the colour that you wish to alter. If the input profile selected is RGB then the sliders change to RGB. If it is CMYK then the sliders change accordingly.
 - Influence - Choose the area around the specified colour that will be affected. This is determined as a scale of 1 to 5 with 1 being the least influence and 5 being the greatest influence i.e. a greater number of colours affected around the selected colour.
 - Tweak Value - Use the CMY sliders to add to or subtract from the colour to be adjusted. Make the colour darker or lighter by adjusting the slider accordingly.
 - Rendering Intent - Choose the rendering intent that the colour is to be altered in. Options are Perceptual, Colorimetric or Saturation.
-  This must match the rendering intent of the Pagesetup for the mapping to work.
- New Tweak - Creates a new Tweak in the rendering intent selected. This can also be achieved by right clicking in the rendering intent window and selecting New.
 - Copy - Used to copy the selected Tweaks. Select the tweaks by clicking with the mouse. Use the shift for block selection and the Control (apple) key for multiple selection. The Copy option is available by right clicking over a tweak after selecting one or more tweaks.
 - Paste - Used to paste tweaks from the clipboard to the rendering intent selected. The Paste option is available by right clicking after tweaks have been copied.
 - Change White Point - Allows you to change the white point of the paper. Select the button and enter the X,Y,Z points. If you have a spectrophotometer connected you can measure the white point directly into the system.
 - Zoom - You can zoom in and out of the LAB colour space so you can see the point that you are tweaking in relation to the whole space.
 - L-Value - You can move up and down the L value so that you can see the point you are tweaking in relation to the Lightness.
 - ICC Profiles - Choose the input and output profiles that you are using to tweak. These must match the ones selected in the Pagesetup as they get stored with the Tweak Set and are used during the mapping process.
 - Spectrophotometer - Choose an on-line spectrophotometer that you have connected to read values directly into the Tweak Set. Once selected press the Activate to connect and take measurements.
-  If the device is being used by another application (including a Serendipity Blackmagic application) then it will fail to connect.
-  **HowTo**
1. Create a new Tweak Set by selecting New from the menu or apple N. (control N on Windows).
 2. Choose an input profile. This must match the input profile selected in the Pagesetup that you are creating a Tweak Set for.

3. Choose an output profile. This must match the profile selected in the Pagesetup that you are creating a Tweak Set for.
4. Enter the name of the Tweak Set you are creating and press enter. If the name “Untitled” is not selected then select it and wait until it changes for editing.
5. Select the rendering intent for the Tweak Set. This should match the Pagesetup that you are using the Tweak Set with. You can copy and paste colours between rendering intents and all colours can be saved in all rendering intents. Only the colours saved in the Set under the rendering intent that match the Pagesetup are adjusted.
6. Create a New Tweak manually or by reading a colour with an on-line spectrophotometer.
7. Select the colour space that you are going to use to create the colour. (If using the spectrophotometer then the colour space changes to LAB and shows the colour values read.)
8. Create the colour you want to adjust by moving the sliders or entering the values in the boxes. If using a Spectrophotometer then the values are entered automatically.
9. Change the influence value to affect more or less colours around the values entered.
10. Make adjustments to the colour as desired.
11. Repeat for all the colours you want to create in the Tweak Set and save.
12. Go to the Pagesetup and select the Tweak Set under the ICC section and save.

Job Genie

Overview

The Job Genie is used by some RIP input filters for polling. For these types of RIP the jobs are polled and stitched together based on their naming convention. For example, Tiff Based (Generic) input filter takes jobs from RIPs that produce 1 bit Tiff files. These RIPs are very common and produce a wide range of naming conventions. When the naming convention is standard such as “jobname_platenname.tif” then the generic Tiff input filter can poll these correctly. But when the names are more unusual such as “J3717p1S1CCyan.tif” you need to use a Job Genie to poll and stitch the names together into a single job. With the Job Genie you can specify the make up of the job. What parts of the name are the jobname and what parts the plate. The available options for the interface are detailed below.

The configuration window is split into two sections. The column on the left allows you enter a task. See Tasks below. For each Task there are four sections that require consideration as shown by the window on the right. This allows you to configure what files are collected, how the job names are made up, how they should be stitched together and how they are displayed in the RIPMonitor. These sections are separated into tabs which need to be configured in turn.

Tasks

For each Job Genie that you select in a RIP input filter there will be one or more tasks. For each task you specify how the job names are collected, how they are made up and how they are displayed. You may need more than one task to collect all the files in a given path if the naming varies. Jobs are constructed in the order of the tasks. Once a jobname is matched by a given task then that jobname is removed from subsequent searches by following tasks. Therefore the order of the tasks is important.

Ordering

To change the order of a task, select it with the mouse and drag it to the position in the list as desired. The options associated with the tasks are

- Log - This displays the matching process in the Server log for the task selected. This can be

useful to debug problems where configurations are not matching files properly.

- Add - Adds another task to the list. To change the name of the task, select the name and wait for it to change to edit mode. Enter the name and press enter or click anywhere in the window with the mouse.
- Duplicate - Copies the currently selected Task to a new one.
- Delete - Deletes the currently selected Task.

Tab 1 - Collect Files

This specifies how files are collected together. The files collected are then sorted according to the configurations in the other steps. Files are collected by defining two parts. First is the action and the second is the definition. The definition has a text box for you to specify the characters that make up the definition and are to be matched according to the action. The options are

Actions

- ignore files - Do not include any files that match the definition specified when the input filter collects them ready for sorting.
- ignore directories - Do not look in directories that match the definition specified when collecting files ready for sorting.
- descend directories - Only look in directories specified by the definition to collect files ready for sorting.
- include files in directories - Include all files in the directories specified by the definition when collecting files ready for sorting.
- include files - Only collect files specified by the definition.



With the above actions the “include files in dir” has precedence over all the other actions. If this is matched then files and directories at the same level are ignored. Files and directories inside the directory that is matched are then subjected to a search governed by any other action specified.

Definitions

- ending with - Any file or directory as specified in the action with a name that ends with this.
- beginning with - Any file or directory as specified in the action with a name that begins with this.
- containing text - Any file or directory as specified in the action where a name contains this text.
- named - Any file or directory as specified in the action that is explicitly named this.
- Filename Length - You can specify a minimum and/or a maximum filename length when searching for jobs for sorting.

default - 0 (disabled)

- Add - Adds the action and definition specified to the list of files to collect.
- Apply - Applies changes to the currently selected action and definition in the list.
- Delete - Deletes the currently selected action and definition from the list.



The Add, Apply and Delete buttons are only available if the action is valid. e.g. if there is a change to an existing entry then the Apply becomes available. If actions are not added or applied to the list before a Save then the list is not updated.



HowTo

1. Add a new Task and change the name if desired.
2. Select an appropriate action.
3. Select an appropriate definition
4. Enter the characters that you wish to match according to the action and definition configured.
5. Click Add to add the item to the list.



If you do not enter anything in the collect files tab then all possible files in the path will be collected and passed on for sorting. This is less efficient and can take a long time if there are a lot of files in the path that are not the jobs you

want to find. It is better to try and specify only to collect files that match the jobs that you want and ignore all others.

Tab 2 - Filename Break Down

This allows you to specify the construction of a filename. This is done by breaking it down into parts and giving each part a user definable name. Once all the parts of the filename are identified they can be grouped together to make complete jobs. With most jobs there are common elements which would make up the job name and there are unique elements which may identify the plate colour or specific file marker. The options for Filename Break Down are

- Case Sensitive Matches - This is used to match case when the criteria for matching contains user specified input. i.e. “Part contains specific words”, “Match to separator” and the “Truncate” option. If any of these are used and the case sensitive matches is selected then only those characters that match the specific case entered are matched.
- Read Direction - This is the direction that we read the filename. You can choose to read it from left to right or from right to left. Click the arrow to change the read direction.



Sometimes it is easier to determine the filename parts by dealing with the endings first. In this case we would reverse the arrow and read from the right to left.

- Parts - This is a block diagram that shows you the break down of the job. Each part is given a name and identifies a section of the filename. Clicking the Read Direction arrow changes the order of the parts to show you which part is going to be read first.



If you are creating a new Job Genie then you will not see any parts in the diagram area until you identify them.



When you come to name the parts it is a good idea to give them meaningful names.

- Add - Add Parts to the list.
- Apply - Update the selected Part with changes.
- Delete - Delete the selected Part from the list.

- Part Name - Specify a name that you want to call the part you are about to describe. This can be anything but meaningful names are useful when choosing the groups later.
- Part Contains - Specify from the pull down list what the part will contain. The choices are.
 - any character - The part can contain any valid character.
 - numbers only - The part must only contain numbers.
 - hexadecimals only - The part must only contain hexadecimal numbers i.e. 0 - 9, A - F.
 - specific words - Specify a specific word or characters in the text box that the part must contain.
- Match - Choose to what point in the filename that you are going to match to. This may be a specific separator or end of string. i.e. read along the filename until this point, looking for the valid Part matching specified above. The choices are
 - to separator - Enter a character in the text box to specify as a separator. i.e. continue reading the part until you reach this separator.
 - to end of string - Match everything from this point to the end of the filename (string).
 - to numeric separator - Match everything from this point until you find a number.
 - to non-numeric separator - Match everything from this point until you find anything that it not a number.
 - to "." (full stop) separator - Match everything from this point until you find a full stop.
 - to "-" (hyphen) separator - Match everything from this point until you find a hyphen.
 - to "_" (underscore) separator - Match everything from this point until you find an underscore.
 - to "\$" (dollar) separator - Match everything from this point until you find a dollar (\$) symbol.
 - to " " (space) separator - Match everything from this point until you find a space.
 - to number of characters - Match the number of characters that are specified in the text box.
 - Truncate from character - You can choose a character to identify in the

filename and remove all characters from that point onwards. e.g. if you have a large number of 0's in a group you can choose to remove those 0's from the group so that they are not displayed.



The "to separator" and "Truncate from Character" options allow multiple entries separated by commas where each entry is searched for a match. i.e. You can specify "to separator a,b,c,d" where if any of the separators are matched then it is valid.

Separator Options

Separators are the characters that determine the end and beginning of a part. e.g. with cyan.tif the full stop (.) between cyan and tif is the separator. As this is part of the filename you still need to decide what to do with this separator. There are three options.

- discard separator - Ignore the separator.
- include separator with this part - Include the separator with part that you are describing.
- include separator with next part - Include the separator with the next part that you describe.

Usage: With a filename such as job.cyan.tif where we parse the name in the forward direction, we describe the first part as name to separator full stop (.) - and the next part as plate to full stop (.) . Discard separator creates the two parts as "job" and "cyan". Include separator with this part (for name) would produce a part as "job.". Include separator with next part (plate) produces a part as ".cyan". This is really only used if the separator is a character that you want to display in the RIPMonitor, say a page marker. The most commonly used option is discard separator. In the example above if we used "include separator with next" then we could not identify the colour as it will be called ".cyan".

Tab (3) - Jobname + Plate

This section allows you to configure which parts should be grouped together to complete a job and which part identifies the plates of the job. You can specify how the plates are described and control specific mapping. The available options are shown below.

Job Grouping

Decide how the files are grouped to form a job.

- Only group files in the same directory as job - check this box to group filenames together in a

directory. Files in different directories will not be grouped into one job.

Usage - Used when job directories are created containing all the plates. Sometimes the filenames vary for the name of the job but because they are all placed in one directory per job they can be grouped together.

- Group files with parts - This displays the parts that were created in Tab 2. Select the part or parts that make up the job name.

Plate Identification

You need to define which part created in Tab 2 is the plate part and how it is written. The options are

- Plate Part - Select the part of the filename that describes the colour from the pull down list. The pull down list contains the part that you created in Tab 2.
- Plates are
 - defined by words - The plates names are complete names e.g cyan, pantone 252.
 - defined by numbers - The plates are defined by numbers. e.g. 0 is cyan, 1 is magenta etc. If this is selected two other options are available.
 - Starting plate number - Enter the number that plates start at. This is usually 0 or 1
 - Plate Order - Choose the plate order between KCMY + specials or CMYK + specials. i.e. the starting plate number as defined above starts as K or C depending on the order.
- Map letters c, m, y, k to process names - If the plates are named with just letters e.g. cyan is represented by c, then select “defined by words” and choose this option.
- Strip leading zeros from colour names - Sometimes colour names have multiple zeros before the plate number. This option can be used to remove the leading zeros.

Plate Mapping

You can map plate names so that they appear correctly in the RIPMonitor. A list of plates that require mapping can be created. The options available for plate mapping are

- Case Sensitive Mapping - Select this if the mapping should check for case.

- Add - Add the mapping into the list.
- Apply - Apply changes to the currently selected mapping.
- Delete - Remove the currently selected mapping from the list.
- Prefix number literals with user text - You can add a prefix to numbers that you are polling. e.g. if the colour is called 254 you can prefix the word pantone in front of the number making the special plate become pantone 254.



HowTo

1. Enter the colour name you want to map.e.g. 100
2. Enter the new colour name. e.g. 100 CVC
3. Click Add.
4. Repeat as needed for all the colour names that you wish to map.

Tab (4) Display

This section allow you to configure how the job names are displayed in the RIPMonitor. The options available are

- Display Specification - This shows the parts that were created in Tab 2.
- Jobname String - This shows what will be displayed in the RIPMonitor for each job. You can enter any valid character or use group parts.
- Job Directory - Allows you enter the job directory into Jobname String field.



HowTo

To display the Job Name in the RIPMonitor select the Part displayed in the list that was created as the Job name. This may consist as one or more parts. e.g. you may want to select a job name and an edition name. Click the Job Directory to display the directory name that the files are found in. To display parents of directories change d1 to d2. The higher the number the higher up the directory structure you will display. Each time you select a Part or Job Directory it enters

or removes the item from the Jobname String field. The items are added at the current cursor position. You can add spaces, any other characters or text as desired at any point of the field.

Usage - Use the directory in the Jobname String field when “only group files in same directory as job” is enabled. This is because the filenames usually have no real meaning but are all grouped into one directory where the name of the directory is the job name.

Output

Overview

This section describes the Output module of the Workbench. The Output handles processed jobs and determines where the file is going and what format is created. The format that is produced is determined by the “Output Driver” and the method of delivery is determined by the “Destination”. There is one other section to the Output called “Collating” which are the details for the Nesting and Duplexing features.

Queue

This section handles the output format and queue parameters. The options are

- Output Driver - Select the desired output driver from the list available drivers. The available drivers depends on the options enabled on the dongle.

Effects - The selected driver affects the options in a Pagesetup that point to it. For example, if you select an inkjet output device as your driver, then only the supported resolutions and colour spaces available in the Pagesetup for selection are those supported by the device chosen. If you select a file format such as Tiff Image then any resolution can be entered in the Pagesetup.

 The Output driver must be selected before the Pagesetup can be created.

- Status - Choose whether the output queue is on (Active) or off (Inactive).

 This can also be controlled from the QueueManager.

- AutoPause - Select a time duration that the queue should pause for after processing a job.

Usage: Mainly used for double sided plotters so that there is a pause in sending the next job giving the plotter time to turn a sheet ready for the back side to be printed or time to load another sheet.

- AutoClean - This determines the number of jobs to keep in the output queue. Once the set limit is reached the oldest jobs are removed.

Default - Off - no jobs are removed.

Destination

This section determines the method of delivery of the print job to the final destination. Depending on the destination driver selected there may be some additional options. The drivers and options are:

- Command / script - You can select a script or command to be run once a job has completed.
- Epson FireWire - This is to drive an Epson printer with firewire.



This is only available for the Mac OS X version. To print via FireWire on a windows machine you need use the Local Printer option. See Local Print Queue.

- Custom Settings - Choose the Epson FireWire device you have connected. These appear as EpsonFirewire[1] for the first device found. The second device is called EpsonFireWire[2] and so on. These are determined by the order that the devices are plugged into the Mac and turned on.



If this order changes i.e. you turn your devices on in a different order then the destinations will need to be changed otherwise your queues will be set to print to the wrong device.

- FTP - You can send your completed job to a remote machine using ftp. Enter the Username, Password and Hostname/IP address of the remote machine and the path that you want the files to be sent to on the remote system. The path must be valid and must have write permissions.
- Local Device - If you have a printer connected as a serial or parallel printer then you can send your file direct to the device. For example, for a printer connected to the first parallel port on your local machine you enter LPT1 as the path.
- Local Folder - Choose a local folder to send the output file to. Enter the path or select the “Choose” button to browse and select a folder.



The folder must exist and have write permissions.

- Local Print Queue - You can print to a local print queue.



HowTo

1. Create a local printer and test it.
2. Enter the exact name of the printer in the Path.



You can also use this to print to a windows printer on another machine. In the path location enter \\<machine>\<printer> where <machine> is the name of the windows machine that has the printer and <printer> is the exact name of the printer. The printer must be shared.

- LPR Port - You can use LPR to print jobs to printers that accept it. Enter the Hostname /IP address of the printer and the path.

Usage: Not all devices require a path to be entered. This is a good option for Epson printers that have a network card. Just enter the IP address of the printer (no path required) and save. This method is faster than TCP/IP printing for these devices.

- Nowhere - This is mostly used for internal testing. Files created by the print driver are not sent anywhere. They are left in the default raster location. see Directory Structure.
- Customise - You can select a print time to simulate for testing purposes.
- PAP (Appletalk) - You can select a networked Appletalk device to print to. Select the “Change” button to bring up a chooser showing valid Appletalk devices.
- TCP/IP port - Print to a networked device over TCP/IP. Enter the Hostname or IP address and select the port number of the device. See Networked Printers for more info.
- USB Printer - Prints to a printer connected via USB.
- Custom Settings - Allows you to select available printers connected via USB and turned on. Printers are shown with full descriptions.



Only available for the Mac OS X version. To print via USB on a windows machine you need use the Local Printer option. See Local Print Queue.

Collating

Collating is a method of gathering various outputs and grouping them together. There are two methods of collating available depending on the Output Driver selected. If you select an output driver that supports duplexing then the additional duplexing collating method becomes available. Otherwise the only available option is Nesting. The parameters vary depending on which one is selected. All options are shown below.

Duplexing

You can duplex jobs with multiple pages to form double sided printing. This is only available for printers that support duplexing mode. See Duplexing for a list of supported drivers. The options are

- Add Separator Page - Adds a blank page in between duplexed sets.



This is useful when de-imposing and duplexing perfect bound jobs. A blank page is inserted after the “Maximum jobs” is reached for duplexing to start. e.g. If you are duplexing 16 page sections then set the Maximum jobs to 8 (8 duplexed jobs) and a blank page will be added to the output after each 16 page section.

- Top Page - Determine if the top page is an odd or even number.
- Maximum Wait Time - The time to wait before duplexing begins.

Effects - If the Maximum wait time is reached and the back side of the pages have not yet been processed the queue will still begin to duplex those pages available. This will result in single pages where the backs have not yet completed.



This can also be controlled manually via the QueueManager.

- Maximum Jobs - Set the maximum number of jobs for duplexing. If this value is reached then duplexing will begin. See also “Add Separator Page” above.



See Duplexing
HowTo

Nesting

You can nest multiple jobs together for a single output to save media and time. The parameters for nesting are as follows

- **Enable Automatic Nesting** - You can set the queue to nest jobs automatically when the configured conditions (such as maximum wait time) are met.
- **Auto rotate when nesting** - Enable auto rotation when nesting occurs.

Usage - You can set up a Nesting queue for jobs that may be less urgent. Therefore you can send jobs to the nested queue as desired and when the conditions are met, nesting will begin. If you choose the auto rotate when nesting option the jobs may be rotated when nesting occurs. This is determined by the nest criteria and jobs waiting to nest in order to find the most efficient use of the nesting area.

 If you select the auto rotate option then you should make sure that the Rotate option in the pagesetup is set to None. There is no need to spend processing time to rotate a job if it is going to be rotated at nesting time. See rotation method under the Pagesetup section “Sheet” on page 63

 You can nest any job that is in a queue at any time if this is not enabled. Some parameters are still used to determine the nest sizes and conditions.

- **Copies** - Specify the number of copies you want of the nest. e.g. if you have 7 jobs making up a nest and enter 5 in the copies field, you will get 5 copies of the same 7 jobs nested and printed.
- **Maximum Wait Time** - Specify how long to wait before nesting begins. Once the time is reached, nesting will begin and any job that is waiting to nest will be nested into a single job. The start time is determined by the first job that appears waiting to nest.
- **Minimum Paper Coverage** - Specify the minimum paper coverage that must be reached by jobs waiting to nest before nesting will begin. Once reached any jobs waiting to nest will be nested into a single job.
- **Maximum Jobs** - Specify the maximum number of jobs in a nest. If there are more jobs in the queue than the number specified then that number of jobs will nest and the remaining jobs will stay waiting to nest until the cri-

teria is reached again. e.g. Maximum Jobs specified as 5 and there are 7 jobs waiting to nest then 5 will nest and 2 will be waiting.

- **Media Width** - Specify the media width.



This parameter is required for nesting to work.

- **Gap Between Jobs** - Choose the gap between the jobs in a nest. Choose between small or large. The values are
 - Small = 0 - 0.5 inches
 - Large = 0.5 - 1 inch
- **Minimum Total Height** - Specify the minimum total height of a nest. i.e. The combined height of the jobs waiting to nest must reach this before nesting commences.
- **Maximum Total Height** - Specify the maximum total height of a nest. i.e. If the combined height of the jobs waiting to nest reaches this then nesting will commence.



The Minimum and Maximum height settings are calculated along with the media width specified.

Pagesetup

Overview

A Pagesetup consists of many modules that can be configured to manipulate your job for the desired output. You set up page sizes, orientation, colour management, screening and printer publishing amongst other options. Some of the modules are relevant to the Output Driver and will change depending on which one is linked to the Pagesetup. Each module deals with a related area and those that are not relevant can be hidden for a simplified view. Each module is described below.

Pagesetup Modules

Output

This module selects the output for the Pagesetup and the subsequent properties. To change the output choose the Change Output option. From here you can select an output that has previously been made, edit it or create a new one. You can also enter a search string to filter the list in the search filter box below the list. See “Output” on page 54 for more information on creating outputs. The options available for Output are as follows.

- Resolution - Select or enter the resolution of your choice. If the output chosen is a printer then only the printers supported resolutions are available. If it is a file format then you can enter your own value.
- Colourspace - Choose the output colour space as desired. This can be either Gray, RGB, CMYK or CMYKOG depending on the output chosen.



The setting here affects the ICC profiles that you can choose for the output.

- Antialiasing - Choose 2x2, 3x3 or 4x4 or none. Antialiasing is designed to smooth jagged edges and is mostly used when the output does not have sufficient resolution to display edges smoothly. It does this by adding shades of grey or colour around edges to blur them. The values increase the amount of pixels used for antialiasing.

Effects - The greater the amount of antialiasing the longer the processing time. This also has a greater affect if rotating the job.

When to use - When creating JPEGs, TIFFs or PDFs for display on a monitor. Or when output is set to low resolution.

Default - None



You should not use Antialiasing when the input screening is set to Preserve and your incoming data is screened.

- Priority - You can assign a Priority to a Pagesetup. The higher the number the higher the priority. Pagesetups with a higher priority are sent jobs ahead of those with a lower priority. i.e. Jobs waiting to Image or waiting to Render will process through Pagesetups with higher priorities than jobs submitted to lower priorities queues. Numbers can be negative.

Default - 0

Custom Settings

This varies depending on the output chosen. It controls properties that are specific to the output driver selected. e.g. if JPEG is chosen as the output then the customise section allows you to select the Quality. If the output is for an Epson device then the customise allows you to select items such as paper types, ink types and cut methods. Choose Edit to select the options required.

Publish

This module allows you to choose how you publish the Pagesetup so that you can send jobs to it. The options for publishing are

DropFolders

Publish a DropFolder for the Pagesetup. This allocates a folder where files can be dropped in for processing. See file types on page 59 for valid formats.

- Mac or Windows - Choose to publish a folder for Mac or Windows.
- Location - Select a folder as a drop folder. The folder must exist and have read and write permissions.
- Default - Resets the drop folder location to the default one.

Default location - Serendipity Blackmagic install dir/
drop/<“Pagesetup name”>

Valid file types - Postscript, PDF, JPEG, TIFF Image,
Serendipity Blackmagic Image, EPS, PNG.



See “Publishing drop folders...”
HowTo

Printers

You can publish the Pagesetup as a printer so that machines on the network can select it and print direct from applications. Options are

- Mac or Windows - Choose to publish a printer for Mac (appletalk) or Windows. The Pagesetup name is used as the printer name.



See “Publishing a Printer...”
HowTo

TCP Port

You can publish the Pagesetup as a TCP Port to allow unix based computers or other Serendipity Blackmagics to print to it. The options are

- Activate port number - Select this to show a text field allowing you enter a port number. The computers hostname or IP is used and each Pagesetup has its own port number.



See “Publishing a TCP Port...”
HowTo

Colour Correction

There are a number of tools that you can use to manipulate or fine tune the colour to achieve the results that you want. The options available are as follows.

- Replace Colour Set - Select a Replace Colour Set from the list of available sets. From the pop up chooser you can preview the set, edit it or create a new one. See “Replace Colour Set” on page 76 for more info.
- Process DotGain Curve - Select a DotGain Curve to be applied to the Process colours only. This is one curve that effects all process colours. From the pop up chooser you can preview a curve, edit it or create a new one. See “Dot Gain” on page 42 for more info.
- Specials DotGain Curve - Select a DotGain curve to be applied to the Special spot plates

only. One curve effects all special colours the same. From the pop up chooser you can preview a curve, edit it or create a new one. See “Dot Gain” on page 42 for more info.

- Correction LUT - Select a correction LUT to be applied. From the pop up chooser you can preview the curves, edit them or create new ones. See “Gradation Curve” on page 44 for more info.
- Linearisation LUT - Select a linearisation LUT to be applied. This is normally done as part of the standard calibration process with the use of the Lineariser. See “Lineariser” on page 100 for more info. From the pop up chooser you can preview the curves, edit them or create new ones. See “Gradation Curve” on page 44 for more info.

ICC Profiles

This is where you can choose if you use ICC profiles as your calibration method. You can choose which rendering intent is used and the profiles for calibration and colour space conversion. ICC profiles are used to match colours from one device, say a press, to another device, say an inkjet. It does this by mapping an input to an output colour. See the “Calibration Guide” on page 118 for more information. The options available for ICC Profiles are shown below.

- Always Use ICC - Enable this to always use ICC profiles. If this is not enabled then the ICC profiles selected are only used in colour space conversion.
- Intents - Choose the desired rendering intent to use. The choices are
 - Perceptual - All colours are moved proportionately to each other so that the eye perceives the colours to be correct. i.e. Colours that are out of gamut move into gamut and those that are in gamut move proportional to the ones out of gamut.
 - Relative Colorimetric - Those colours that are out of gamut are moved into gamut and those in gamut are left untouched.
 - Absolute Colorimetric - The colours are left alone so those that are out of gamut will not be able to be reproduced.
 - Saturation - Those colours that are out of gamut move into gamut but all colour increase in Saturation as a result.
- Retain Pure Black - When ICC Profiles are used then all colours, even solids are made up

of a mix of different colours. This generally means that black text contains more than black. Selecting “Retain Pure Black” uses black only for areas that contain just black.



Not suitable for devices with light black as these tend to look brown at the highlights and midtones. Therefore ICC profiles are needed to correct and make the black look black.

- **Input RGB Profile** - Select an RGB Input profile. This is used to convert input data that is in RGB to LAB. This should be a scanner or digital camera profile.
- **Input CMYK Profile** - Select a CMYK Input profile. This is a match profile and is used to convert input data from CMYK to LAB. This should be a press profile or similar device you want to have your output matched to.
- **Output ICC Profile** - Select an Output profile. This is the printer or other output profile and is used to convert the LAB data to the output colour space. This output could be RGB, CMYK or CMYKOG depending on the output device chosen and the colour space selected.
- **Output Tweakset** - Select a Tweakset from the list of available sets. From the pop chooser you can preview the set, edit it or create a new one. See “ICC Tweak Set” on page 46 for more info.
- **Device Link Profile** - Select a device link profile. Selecting this disables all the other ICC settings.

Colour Keys

Colour Keys allows you to merge some plates and separate others from a single job submission. e.g. You can merge the CMYK plates together and print the 3 specials as separate jobs. Or you can create a progressive proof with C, CM, CMY, CMYK, CMYKS1 etc. The list on the left shows available plates and the list on the right show the assembled colour keys. The order of the keys dictates the print order. Options available as shown below.

- **Enable Colour Keys** - Select this to turn the colour keys module on.
- **Plate** - List of available plates.
- **Add** - Adds the select plates to the Plate combinations list on the right.

- **Progressive** - Used to make progressive proofs. See “HowTo” below.
- **Deselect** - De-selects any plates currently selected in the plate list.
- **Remove** - Removes the selected Plate Combination from the list.
- **Remove All** - Clears the Plate Combination list.



HowTo

To build a Progressive Proof

1. Select the first plate that you wish to have in the progressive e.g. Cyan.
2. Click the “Add 1 Plate” button to copy the plate into the plate combinations list.
3. Click the “progressive” button to add the first plate and next plate in the list as a merged job.
4. Repeat to continue adding the next plate in the list.



HowTo

To build selective Colour Keys

1. Select the plate or plates from the available list.
2. Click “Add” to create an entry in the plate combinations list.
3. Repeat with the plates as desired.
4. Deselect a single plate by clicking the plate again.
5. Choose the “Deselect” button to deselect all plates currently selected.

Screen Printing

This mode separates a job into single plates and prints them as black. This is designed to print with a halftone dot onto a clear film media. To increase the density of the output you can choose a combination of inks. This can be used to produce films for use in the Screen Printing Industry. The options available are shown below. See “Screen Printing” on page 132 for more information.

- **Enable Screen Print Mode** - Turns the screen printing mode on.
- **Ink Combination** - Select the inks to be combined for a single separation output.



In screen printing mode all jobs are separated and you must have a Paper Profile where only one dot for each colour is on. See “Screen Printing” on page 132 for more info.

Output Screening

You can apply screening to the output file if desired. There are a number of screening types and options available. See below for an explanation of each. This is only available if the Output driver supports Screening.

- Method - Choose the preferred method of screening. The options are
- FM Screening - There are a number of variations on FM Screening. These are
 - Stochastic - Standard Stochastic screening.
 - Stochastic-2 and 3 - Stochastic screening with progressively increasing amounts of noise mixed in. This is done to overcome some artifacts caused by InkJet printers.
 - Stochastic Fast - A fast version of the Stochastic screening mode. Slightly lower quality than Stochastic.
 - Error Diffusion - Error Diffusion Screening.
 - Ordered Dithered - Ordered Dithered Screening.
- Halftone Screening - Select halftone to place a traditional rosette dot on the output. The available options are
 - Dotshape - Choose the dot shape to suite your requirements from Round, Inverted Round, Elliptical, Inverted Elliptical, Diamond, Euclidean or Line.
 - SuperCell - Choose SuperCell screening instead of standard halftone.
 - Angle, degrees - Enter the desired angle for each plate.
 - Screen, LPI - Enter the desired screen ruling for each plate.
 - Defaults - Use this to select a default value based on the output resolution.

Usage: Because inkjet printers are generally low resolution compared with an imagesetter or CTP device you cannot achieve a very high LPI with these sorts of devices. Typically with a device that is run at 720 x 720 dpi, you can run it up to about 65lpi. With variable dot printers you can get away with a higher LPI but this is still not very good for contract quality proofing. If you wish to add good halftone dots on the proof then you must create a 1 bit Tiff file at high resolution and high LPI, and then use the Tiff generic

input filter to read the files in with preserve screen set. See “Adding dots to contone data (ref)”. The exception to this rule are screen printers as they are generally running jobs at 65 lpi or lower. The SuperCell screening produces a much better quality output than standard halftone and is recommended.



The special colour angle and lpi assigning is done in order of specials found. Each is assigned in turn and if you have more specials than the 8 available the first one is used again for assigning plate angle and ruling.

Input Screening

The input screening module determines how the screening on the input data is to be handled. There are two main choices and the options available for each are as follows.

- Handling - Select the method used to handle incoming screening data. The choices are
- Descreen - Descreens the incoming data with either
 - D-Dot - removes the dots.
 - Fast - Quick descreening algorithm

Usage - D-Dot is used where the output job is being sent to a photocopier or similar device which has a front end RIP that applies a screen of its own. If you did not remove the dot the job would be double screened, producing poor output. Use fast for all other methods when the incoming screening is not to be preserved.

- Preserve - This preserve the dots from the incoming data so that the same dots on the final job are shown on the proof. The choices are
 - Real Dot Technology (RDT) - Used to preserve the dot structure.
 - Fast2 - Similar to RDT but a faster method.
 - RDT Smooth 1, 2 and 3 - This is RDT with progressive levels of smoothing.

Usage - The Fast2 method should be used where the dot structure is not very important. It will preserve the dot but it is a quick low quality method The sharpest dot structure will be achieved using RDT. However you will sometimes get introduced moire caused by the head weaving of the printer, the resolution and screen ruling of the original file. You can compensate for this by selecting the RDT smooth 1, smooth 2 or smooth 3 options.

Effects - Increasing the level of smoothing will take longer to process and the dot structure will become progressively less sharp with each level increase.



This is only used on screened input data and not contone jobs.

Postscript Options

These options are only used when the incoming data is Postscript. The choices are shown below.

- Use Bounding box - Some Postscript jobs do not place a pagesize in the job information. Checking this will use the bounding box as the pagesize.
- Simple RGB to CMYK Conversion - This is a compatibility mode from older versions of the product. Images are converted from RGB to CMYK quickly using a basic method. The colour is not very accurate and not recommended for contract proofs.
- Fail on RGB Images - This causes a job to fail if it contains RGB images. If this is not checked the jobs will process but RGB images will be ignored and not print.

Resampling

This section allows you to configure the method for sampling the incoming data and changing the resolution from the input to that of the output. The choices are

- Nearest Neighbour - This is the fastest method but less accurate. Choices are made as the closest pixels from input to output and can result in jagged edges or stepping effects.
- Bi-Linear - This is a medium quality sampling method and take longer than Nearest Neighbor. This takes the weighted average of 4 pixels from input to output.
- Bi-Cubic - High quality sampling method which takes longer to calculate than Bi-Linear. It uses the weighted average of 16 pixels from input to output
- Filtered - Serendipity's own sampling method giving the highest quality. It takes longer to process than Bi-Cubic and uses an averaged area from input to output.

Effects: Each of the resampling methods take more time to process than the previous one, increasing from Nearest Neighbour as the fastest to Filtered as the slowest. Each process provides smoother output than the pervious one.

Usage: For contone data such as Postscript and PDF Filtered provides better resampling. For screened data Bi-Linear provides a good compromise between output quality and processing time.



When input screening is set to Preserve then the setting here is ignored.

Logo

You can position your own company logo or sign off slugline anywhere around the job. The options available are shown below.

- Enable Logo - Turn the logo effect on or off.
- Dimensions - Enter the dimensions you wish the logo to come out.
- Logo File - Select this button to choose your logo file.

File type - EPS

Usage - You can use this for placing a colour bar on the side of a job to check for consistency. The logo passes through the same colour management as the job and can therefore be verified.



The file is not rotated during the output. Therefore if you position the logo file along the left or right side the EPS file should be created in the appropriate orientation.

Effects

Various effects can be applied to jobs passing through the Pagesetup. Effects are applied in order that they appear. Some effects have separate attributes to customise them to suite your needs and these can be edited once they are in the Applied Effects column. The available options are as follows.

- Enable Effects - Turn the effects on or off.
- Available Effects - A list of all the effect available. These are

- **Border** - Places a boarder around the job. You can specify the line width and colour by choosing edit.
- **Centering** - Centers the job in the page area specified.
- **Cropmarks** - Places cropmarks around a job. You can specify line width, line length and clearance by choosing edit.
- **Margins** - Specify margins around the job.
- **Mirror** - Mirrors the job.
- **Negative** - Negates the job.
- **Pagenumber** - Places the pagenumber in the middle of the page as a watermark. You can configure scale factor and opacity. You can also choose between page number of the job or the page number of the signature (when using de-imposition).
- **Signature Decorations** - Allows you to place page lines (from the signature), and page numbers on the job. The options for this are

- **Drawing mode** - Choose how the numbers and lines are to be printed between Merge or Overprint.
- **Print page numbers** - Select the checkbox to enable the printing of page numbers.
- **Text Scale Factor** - Enter the size of the text as a factor of the page size in %.
- **Text Colour** - Select a colour for the pagenumber to be printed in.
- **Print trim lines** - Select the checkbox to enable the printing of the trim lines.
- **Trim line mode** - Choose between spreads or page for the lines.
- **Line width** - Enter the width the line will be drawn with.
- **Units** - Select your preferred units for the line width value.
- **Line Colour** - Select a colour for the line to be printed in.



TIP

Choosing lines for spreads will print a line around a paired page i.e. the spread. Choosing lines for pages will print a line around a page. So if you are printing paired pages then a page line will show where the single page fits on the spread and show two page outlines on the single spread.

- **Slugline** - Places job info on the job. There are a number of options available for this which are

- **Full** - Shows everything that is configured.



TIP

If you are using narrow format paper and want to have the Full slugline but it does not fit on the paper you have you can select custom and turn all the options on. This will show an item per line e.g. If you select colour correction then the attributes that effect this will be placed on one line. See custom below.

- **Brief** - Shows Jobname, Pagesetup used and Date.
- **Signature and Pagenumber** - Shows the Signature Group, Signature and pagenumber.
- **Custom** - Allows you to select the fields to display.



Fields selected will only be printed if they are relevant to the job. i.e. If you select the field cropping and Rotation but cropping is left on 0 and rotation on None then these will not be displayed. You therefore could have a number of fields selected but nothing printed on the sheet.

- **Watermark** - Places a watermark across a job. You can select the watermark file, the scale and the opacity (transparency) of the watermark by choosing edit.

Sheet

The sheet attributes allow you to manipulate the job in various ways. The options are as follows.

- **Fitting Method** - There are various fitting methods available. These are
 - **None** - Do not do any fitting.
 - **Fit Width** - Shrinks the job to the width specified in media width if the job is larger. The height is sized proportionately.
 - **Fit Height** - Shrinks the job to the height specified in media height if the job is larger. The width is sized proportionately.
 - **Fit Width Height** - Shrinks the job to fit width or height specified in media width and media height. Chooses the most appropriate dimension and scales the other proportionately.
 - **Scale** - Scales a job to the amount specified.
 - **Tile** - Tiles a job that is larger than the specified tile size in media width and media height. You can specify an overlap as required.

- De-Imposition - You can de-impose a large job by using a de-imposition signature. You can create a signature with the signature editor and select it here. See “Signature Group” on page 84 for more info.

Usage - This can be used to take an imposed file like an 8up, de-impose it into 2ups or singles and print it on a smaller printer or produce a single page PDF files.

- Media width - Specify the width of the media.
- Media Height - Specify the height of the media.

Usage - The Media width and height is used by the fitting methods, the rotation options and the centreing.

- Rotation - Choose the rotation required from
 - None - No rotation
 - 90 - Rotates the job 90 degrees clockwise
 - 180 - Rotates the job 180 degrees
 - 270 - Rotates the job 270 degrees clockwise.
 - Auto - Rotates the job to fit best using the media width and height specified.

Usage - Auto is very useful for saving media. If the job fits better rotated saving media then the job will be rotated, or if the job does not fit along the width or the height then it will be rotated to fit. If you are using roll media then width only needs to be specified. If you are sending to a nesting queue then you may prefer not to rotate and calculate the size of the jobs and the number you can get across the sheet. See also “Auto rotate when nesting” on page 56

Effects - Rotating a job will take longer. The larger the job the longer it will take. More memory can assist in the speed of rotating. Rotation takes place at the beginning of rendering and so will effect things like cropping and margins.

- Centreing - You can centre a job if desired. Choose between
 - Vertically - Centres the job vertically according to the media height specified.
 - Horizontally - Centres the job horizontally according to the media width specified.

Usage - You can use this if you need to centre a job at anytime. In particular you may need to use it when printing to a double sided printer to help match your front and back sides.

- Accuracy Correction - You can compensate for media stretch or paper feed errors by specifying a correction amount for width and height.



HowTo

One way to do this is create a job with a 1metre square on it and print it. Measure the square after a short time for the media to normalise and enter the value you measure into the width or height. i.e. if you measure a width of 1.03m and 0.95m height then you enter 1.03 in Width and 0.95 in height to correct for the stretch.

- Cropping - You can crop a job in all directions. Enter values for Left, Top, Right or Bottom.



When specifying the cropping you need to take into account any rotation that has been applied as cropping takes place after rotation.

- Margins - You can specify a margin around your job. Enter values for Left, Top, Right and Bottom.

Usage - You may have to specify a margin to shift a job over or compensate to a printers set margin.

- Effects Mirror - This mirrors the job
- Effects Negative - This negates the job.

Pagesetup Pools

Overview

Pagesetup Pools allows you to print to one or more Pagesetups. You can choose to load balance between multiple Pagesetups or print to multiple Pagesetups simultaneously. These can be published in the same way as an individual Pagesetup or you can setup auto proof from a RIP configuration.

Publish

You can publish a pool of Pagesetups so that you can send jobs to the pool. The available options for publishing a Pool are shown below.

DropFolders

Publish a DropFolder for the Pagesetup Pool. This allocates a folder where files can be dropped in for processing. See file types for valid formats.

- Mac or Windows - Choose to publish a folder for Mac or Windows.
- Location - Select a folder as a drop folder. The folder must exist and have read and write permissions.
- Default - Resets the drop folder location to the default one.

Default location - Serendipity Blackmagic install dir/drop/<“Pagesetup Pool name”>

Valid file types - Postscript, PDF, JPEG, TIFF Image, Serendipity Blackmagic Image, EPS, PNG.



HowTo

See “Publishing drop folders...”

Printers

You can publish the Pagesetup Pool as a printer so that machines on the network can select it and print direct from applications. Options are

- Mac or Windows - Choose to publish a printer for Mac (appletalk) or Windows. The Pagesetup Pool name is used as the printer name.



HowTo

See “Publishing a Printer...”

TCP Port

You can publish the Pagesetup Pool as a TCP Port to allow unix based computers or other Serendipity Blackmagics to print to it. The options are

- Activate port number - Select this to show a text field allowing you enter a port number.



HowTo

See “Publishing a TCP Port...”

Job Queuing

You can control the way the pools work and the importance of the queue. The available options are

- Priority - You can assign a Priority to a Pagesetup Pool. The lower the number the higher the priority. Pools with a higher priority are sent jobs ahead of those with a lower priority. Numbers can be negative.

Default - 0

Pool Type

Decide what sort of pool you are going to use between

- Load Balancing - You can spread jobs across the Pagesetups selected in the pool. You can choose between
 - By Print Area - We calculate the area of each job and the queue with the least amount of print area queued is sent the next job.
 - By number of jobs - The queue with the least number of jobs is sent the next job.

Usage - This is ideal for printing to two or more printers that are the same quality, the same media and the priority is to get the job out of the next available printer. Each printer is calibrated separately to ensure quality. By Print Area is more efficient as the larger the print area the longer it will take to image, render and print. The queue loading is determined at the time of imaging. If a print queue is paused then jobs will be sent to queues that are active.

- Prints to All Pagesetups - Choose to print to all Pagesetups selected in the pool.

Usage - This is ideal if you want a job to print locally and remotely. One Pagesetup can be configured to drive a local printer and the other can create a JPEG image and transmit it to a remote Serendipity Blackmagic. Alternatively you may want to create a PDF file to send to a customer at the same time as printing a hard copy.

Pagesetups

This displays all the Pagesetups configured in the system. For each Pagesetup there is a summary of its configuration. These are shown by the column headers which can be turned on or off as desired. Simply right click in the header area and select the columns you wish to view or hide. The columns can be repositioned by selecting the header and dragging it to the desired position.



HowTo

To select one or more Pagesetups to form the Pool you are creating, select the check box to the left of the name. Choose your Pool Type and decide if you are publishing it or just using it from an internal source such as RIPs. Then save the configuration.

Context menu

There is a context menu associated with each module of the Pagesetup Pool. This allows you to colour code the background of the module for a customised view. There is another context menu option available on the Pagesetups list, which is as follows

- Edit Pagesetup - Allows you to edit the currently selected Pagesetup. Choose all sections or a particular module. You can also create a new one.
- Edit Output - Allows you to edit the Output of the currently selected Pagesetup. Choose an individual module or select All Sections. You can also create a new one.

Paper Profile

Overview

The Paper Profile is the first stage of calibration. It matches paper and ink characteristics very closely with the Output driver, resolution and colour space settings selected. With a Paper Profile you can choose the ink droplet size and light ink mix to be used. There are two parts to creating a Paper Profile. The first stage involves the printing of a density chart through a pre-configured Pagesetup, measuring the values and making selections of dots to be used. Some automated tools are available to help good dot selection. The second stage allows you to set ink limits for a mixture of one, two, three and four inks by printing a chart and determining the point where the inks mottle or fail to dry. For a detailed explanation of creating a Paper Profile see the “Calibration Guide” on page 118. The options for the Paper Profile are shown below.

Context Menu Options

The options for printing and measuring charts are available from a pop up context menu by right clicking anywhere in the Paper Profile area. The options are

- Measure Patches - Use this when you have printed the density chart out and want to measure it using a supported instrument. After selecting it you are prompted to choose an on-line device and select the desired density standard. Not all instruments support all available standards. Consult your instrument manual for supported types. See “Supported Density Standards” on page 97. Once the device is ready to read values the measuring window displays.
- Change Pagesetup - This allows you to change the Pagesetup that is currently assigned to the Paper Profile to a different one.
- Print Density Chart - Prints a density chart. Selecting this displays a chooser allowing you to select a Pagesetup to print the chart to.
- Print Inklimit Chart - Prints the ink density chart. Selecting this displays a chooser allowing you to select a Pagesetup to print the chart to.
- Sift - This uses inbuilt intelligence to select the correct dot combination based on the density readings taken and the output device selected in the Pagesetup. After selecting this you are

presented with the DotSieve Algorithm Selector where you can choose an algorithm from the list to match your device.

Sort Options

These are the pull down lists next to the Sift button and selects the sorting order of the measured patches. There are three sort options available (except Black which has two sort options) which are

- Patch number - This sorts the patches in patch numbered order.
- colour density - This is the density of the colour, sometimes called real density. It is the colour content of the patch e.g. for Cyan density this is the value of cyan measured.
- Visual Density - This describes how dark the colour is i.e. how much light the colour is absorbing. It is measured as Black. Some programs measure colours as CMYV where V is for visual (This is not available as a selection for Black as this is the same as colour density).



Sometimes inks can have a high cyan or magenta density i.e. a high content of colour but they are not very dense visually. It is important to select colours that visually increase in density. See “Calibration Guide” on page 118 for more information.

Patches

This area shows the patches that make up the Paper Profile. The number of patches will vary depending on the device and configuration of the Pagesetup that it is linked to. E.g. a variable dot device with light inks will show 16 patches where light inks are used and 4 patches where they are not. Devices that do not have light inks and are not variable dot will only have 2 patches for each colour. You can turn patch on or off by clicking the upper half of the patch. Clicking the lower half of the patch allows you to manually enter density values for that patch number. For colours that have visual and colour densities, select the number that you wish to enter. D for density or V for visual. Pressing enter or Tab stores the value and moves to the next patch for the next entry. Hovering the mouse over the patch number displays a tool tip giving you information about the patch.



When entering values manually it is recommended that the patch sort order is set to patch number.

Graph

This shows the dots that you have selected to be on for each of the colours. The position on the graph gives a proportional representation showing where the dot starts to turn on and off and how close the dots either side are. You can turn the graph plots on or off by checking the tick boxes under the graph. Hovering the mouse over a point on the graph displays a tool tip giving you information about the dot.



If a colour is not shown on the graph but the check box for that colour is ticked on, then the dots selected are a poor choice and are not valid. You need to change your dot selection until the graph displays the colour.

- Yule Nielsen Number - You can set the YN number for the paper you are profiling if you know it.

Default = 2

- Ink Limits - Set the ink limits for the Paper Profile. These are determined after printing a chart and determining the point that a mixture of ink causes problems. Enter the value for each ink combination. For this there are two options
 - Standard - Simple ink limiting based on ink percentages.
 - Enhanced - Optimised for variable dot printers.



With newer printers where the ink saturation is high it is possible to set the ink limits too far up the scale because they still dry with a lot of ink down. But this can cause problems in image areas with real jobs. Do not be afraid to bring the ink limits down. For example with the Epson printers with the K3 inks you can set the ink limits to 100, 175, 230, 250 for the one, two, three and four ink limits respectively.

- Summary - This displays information about the driver and Pagesetup configuration that is important to the Paper Profile.



HowTo

Create a new Paper Profile

1. Create a new Paper Profile. Choose File -> New
2. Select a Pagesetup. (This needs to be pre-configured)
3. Enter the name of the Paper Profile.
4. Select "Print Density Chart" from the context menu. Choose the Pagesetup that you are creating a Paper Profile for and click OK.
5. After a short time (to let the print stabilise) select "measure patches" and choose your on-line densitometer or spectrophotometer. After measurement is complete click OK. (See below for manual entry procedure)
6. Select the dots that you want to use for each colour. Do this either manually or using the Sift option (recommended for novice users). See the "Calibration Guide" on page 118 for information on good dot selection.
7. Save the Paper Profile.
8. Go the Workbench and select you Pagesetup. Choose Paper Profile under the Colour Correction module and select the profile you have just created. Save the Pagesetup.
9. Go back to your Paper Profile and select "Print InkLimit Chart" from the context menu. Select the Pagesetup you are calibrating and click OK.
10. Enter the ink limit values and save the Paper Profile.

For more information on correct calibration procedures see the "Calibration Guide" on page 118.

Manual Entry Procedure

If you do not have a supported on-line densitometer or spectrophotometer you can still create a Paper Profile providing you can read the densities. Ideally you need to read both the visual and real densities of all of the patches as the assessment of which ones to select is based on both. Once done you enter the values by simply selecting the first patch on each colour, enter the density and press Enter. This will automatically move to the next patch. Make sure that the patch sort order is set to "Patch Number". Where a patch has both real and visual densities i.e. anything except Black, make sure that you select the D value to enter the real density and the V value to enter the visual. Pressing Enter will move to the next in the same group i.e. All visuals can be entered first and then all real densities.

You can also import values from a text file. Choose the "Measure Patches" option and select "from text

file” from the list of supported devices. This will display a file chooser allowing you to locate and select a file to read into the Paper Profile. The file format is CMYK space delimited.

Regular Expression *

Overview

The Regular Expression is used in conjunction with the RIPs. It is a filter where by you can have jobs auto proofed based on matching a particular set of rules. A regular expression is constructed here and then selected in the RIP as a filter under the auto proofing section. Once selected, new jobs that match are submitted for auto proofing. All jobs are still displayed in the RIPMonitor.

What is a Regular Expression

A Regular Expression is a method used to match strings, and a string is a one or more characters. This is similar to a search where you enter some text and the results are displayed, like in the QueueManager search function. The result displays anything that matches the characters that you entered. The Regular Expression here is a little more complicated but the principles are the same. You can apply rules to the characters you enter such as include or ignore these items. You can also build multiple expressions to define the jobs that you wish to auto proof.

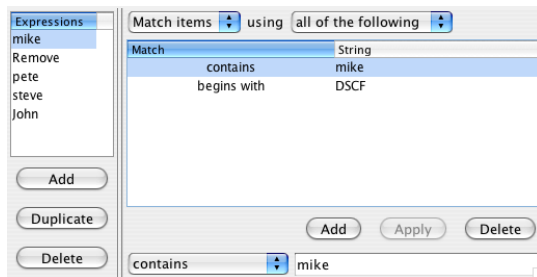

Expressions

The Expressions are displayed and entered in the left list. Each expression is used to match something. You can create multiple expressions to match different jobs or ignore certain jobs. For each expression you enter the string to match and specify the conditions. e.g. what to do if you find anything that matches. The Expressions are handled in the order that they are shown. You can move the expressions around by selecting them and dragging them to the new position. If the first expression matches a job name, and that expression rule is to ignore items then that job is not passed to other expressions for further consideration. So the order can be important if multiple expressions are used. You can change the name of an expression by selecting it and then clicking in the name so that it changes to edit mode. The options available are shown below.

- Add - Adds a new Expression to the list.
- Duplicate - Makes a copy of the currently selected expression.
- Delete - Removes the currently selected expression.

Match List

This is where you specify what you want to match and the rules to apply. You can enter one or more strings to match and apply different rules to each. See examples in the how to section at the end. The options are as follows

- Match Items - Matches the strings entered. i.e. if the string matches a job name then it is retained for further consideration by other expressions. If no other expressions exist then the job would be submitted for auto proofing.
- Ignore Items - Ignores anything that matches the strings entered. i.e. if a job name matches the strings then it is ignored and not submitted for proofing or passed to other expressions for further matching.
- Any of the following - The match is true if any string match condition is met. i.e. if you have two or more match strings in the one expression and either of them match a job name then the Match Items or Ignore Items rule is applied.
- All of the following - The match is true if **all** string match conditions are met i.e. if you have two or more strings in the one expression, all must match a job name for the Match Items or Ignore Items rule to be applied.

String Entry

Enter the string to match. This is a job name or part of a job name. The match then depends on the following conditions that you select with the string.

- contains - The job name contains the entered string.
- begins with - The job name begins with the entered string.
- ends with - The job name ends with the entered string.

- is - The job name matches the string entered exactly.
- does not contain - The job name does not contain the string entered.
- does not begin with - The job name does not begin with the string entered.
- does not end with - The job name does not end with the string entered.
- is not - The job name is not the string exactly.

Buttons

- Add - Add the match string to the list.
- Apply - Apply changes to the selected match string in the list.
- Delete - Remove the selected match string from the list.



HowTo

In this example we will create a regular expression to match some job names. The process involves deciding which jobs you want auto proofed, creating a Regular Expression for them and selecting that it in the RIPMonitor.

List of Job names

DSCF-mike-test2.jpg
 DSCF-mike-test3.jpg
 DSCF-mike-test4.jpg
 DSCF22913-p.jpg
 DSCF22913-t.jpg
 DSCF22913.jpg
 DSCF22919.jpg
 john-DS3test2.jpg
 john-DSCFtest.jpg
 john-DSCFtest2.jpg
 michael-DSCFtest3.jpg
 mike-DSCFtest2.jpg
 mike-DSCFtest3.jpg
 mikes-DSCFtest3.jpg
 pete-DS2test.jpg
 pete-DSCF223test2.jpg
 pete-DSCF223test3.jpg
 petec-DS2test.jpg
 petec-DS2test2.jpg
 petec-DS3test2.jpg
 petec-DSCFtest.jpg

peterc-DSCFtest.jpg
 ppp-petetest3-p.jpg
 sPPP-pptest3-p.jpg
 steve-DSCFtest.jpg
 steve-DSCFtest2.jpg
 steve-DSCFtest3-p.jpg
 steve-DSCFtest3.jpg
 stevie-DSCFtest3-p.jpg
 stevie-pptest3-p.jpg
 stevie-test3-p.jpg

From this list we will auto proof the following

- pete and peter jobs but not petec jobs
- john jobs but not the job john-DS3test2.jpg
- mike jobs where mike is in the middle of the job name only
- steve jobs but not stevie

This is how we do it.

1. Create a new Regular Expression and give it a name.
2. Add a new Expression and change the name to "mike".
3. Choose "Match Items" using "all of the following".
4. Enter the string "mike" at the bottom and choose "contains". Then select Add.
5. Enter the string "DSCF", choose "begins with" and select Add.
6. Add another expression and name it "Remove".
7. Choose "Ignore Items" using "any of the following".
8. Enter the string "DSCF", choose "begins with" and select Add.
9. Add another expression and name it pete.
10. Choose "Match Items" using "all of the following".
11. Enter the string pete, choose "contains" and select Add.
12. Enter the string petec, choose "does not contain" and select Add.
13. Add another Expression and name it steve.
14. Choose "Match Items" using "any of the following".

15. Enter the string "steve", choose "contains" and select Add.
16. Add another expression and name it john.
17. Choose "Match Items" using "all of the following".
18. Enter the string "john", choose "contains" and select Add
19. Enter the string "john-DS3test2", choose "is not" and select Add.
20. Save the Regular Expression.
21. Choose your RIP from the Workbench. Enable "AutoProof", select a Pagesetup or Pagesetup Pool to proof to and select your Regular Expression from the Filter button.
22. Save the RIP.



Most of the expressions can go in any order. But for this example you cannot have the Remove Expression before the mike expression. If you did the jobs that we want with mike in the middle start with DSCF and would be removed from the jobs that match before the mike Expression got to work on them. Therefore they would not auto proof.

Replace Colour Set

Overview

The Replace Colour Set is used to match and replace certain colours as they pass through the system. You can match and replace process or spot colours and choose to match on names or positions. Colours can be created directly or imported from popular desktop applications or the internal Special Colour Set.

Usage - There are a few uses for the Replace Colour Set. It is used to create a digital blue line which replaces all the colours with varying values of blue which allows you to see traps much easier. It can also be used for replacing special colours where the name varies, such as Pantone 101 C and Pantone 101CVC. This way you can catch vary names of colours from jobs and match all of them easily.

Tabs

There are five tabs where colours are created or imported when creating a replace set. Each Tab has a specific function when used to replace colours. Each Tab is described below.

Tab 1 - Process

This Tab allows you to specify any of the process colours you want to be replaced. The left of the tab shows the colour that is used to replace. The right has two boxes, one with a diagonal line and one with the current process colour. These are split with a text field showing the name of the colour placed.

 There are a number of ways you can create a replacement colour for the process colours. These are

1. Select the process colour patch on the right e.g. Cyan. This copies that process colour into the replace patch on the left. With the replace patch selected (i.e. shown in the colour adjustment section), adjust the values as desired.
2. Double click the replace patch on the left. This displays a chooser allowing you to select a colour from a Special Colour Set. Choose a Set and select a colour and press OK. Make adjustments to the values as desired.
3. Drag a colour in from a Special Colour Set or another Replace Colour Set and drop it on the replace patch on the left. Select the colour and make any adjustments required.

4. Use an on-line spectrophotometer to read a colour directly into the replace set.

Tab 2 - Exact

Configure colours for an exact match of an incoming colour name to replace. This is not case sensitive.

Tab 3 - Partial

Configure colours for a partial match of an incoming colour name to replace. This means that if any part of the name matches it will replace. e.g. if you enter 243 in the match it will match Pantone 243 and replace it. The match is not case sensitive.

Tab 4 - Position

This replaces a colour based on the position of a special plate.

Tab 5 - Remaining

This allows you to allocate one colour to replace special plates that are not matched by anything else.



Exact, Partial, Position
HowTo

These three tabs work in the same way. There are a number of options available via the context menu (right click) for adding and configuring colours which are detailed below.

- New Colour - Creates a new untitled colour in the tab. You can then adjust the colour using the sliders on the left and changing its properties. Select the name (Match Plate) of the colour (untitled0001) to change it to the name you are going to match from your job.
- Delete Colours - Deletes the selected colours. This is only available when you right click over the colours. You can also use the keyboard delete key.
- Duplicate Colours - Makes a copy of the selected colours. This is only available when you right click over the colour.
- Rename Match - Allows you to rename the match plate. See the renaming options below.
- Rename Original - Allows you to rename the original name. See the renaming options below.

- Add Colours From Library - Allows you to select one or more colours from any Special Colour Set created in Blackmagic. Choose a Set and select the colours you want and click OK.
- Import Colours - Allows you to import colours from popular desktop applications or previously exported colours from Blackmagic.
- Export Colours - Export the colours to a file. You will be prompted for the file name and destination of the file.



If the set contains a mix of CMYK and LAB colours you will be prompted to choose either CMYK colours or the LAB colours to save.

These cannot be saved in the same file.

Renaming Options

When selecting either of the rename options you are presented with a 'find and replace' window. The options for this are as follows.

- Find - Enter the characters to find in the list.
- Replace With - Enter the text to insert in place of the characters found. You can use any valid characters including spaces. If nothing is entered then any characters found are deleted.
- Ignore Case - Choose whether your match is case sensitive.
- Wrap Around - Continue at the top of the list when the bottom is reached.
- Rename All - Rename all items that are found.
- Rename Selected - Only rename the selected colours if the characters are found.
- Rename Current - Rename the currently selected colour if the characters are found. If more than one is selected then the first one in the list is checked for a match and renamed if true.
- Find Previous - Searches backwards.
- Find Next - Searches forwards.
- Prefix With/Append - These are two more options available from the pull down menu in place of Find that allow you to add characters before or after the names.

Usage - You can use this for fast renaming of all your specials if for example they are named Pantone XXX and you want them to have a Pantone XXX CVC, you can use Append with CVC and rename All or rename Selected.

Column Headings

These give information about the plate and can be turned on or off as desired. Right click in the header area and select the headings you want. Change the order of the headers by selecting and dragging to your preferred position. The headers available are

- Match Plate - The plate name of the job that will be matched for replacement.
- Original name - The original name of the colour.
- Space - The colour Space.
- Mode - The Paint mode of the colour. See Paint Mode.
- DotGain Curve - The name of the dot gain curve applied to the plate.

Colour Adjustment

This section allows you to view and adjust the colour values and properties. The name of the colour selected is shown at the top. A window displays the Original and the Adjusted or Modified colour. With an accurate ICC profile selected in the Client settings the colour represented is accurate. The available options are as follows.

- Colour Space - Choose between LAB or CMYK. The sliders change accordingly allowing you to make your adjustments.
- Paint Mode - Choose the paint mode for the Colour. The choices are
 - Overprint
 - Knockout
 - Primer
 - Opaque

The diagram changes to give you a visual representation of the paint mode. When Opaque is selected a slider becomes available allowing you to choose the opacity of the colour.

- DotGain Curve - Choose a dot gain curve to apply to the colour.



Any dot gain applied to a colour has priority i.e. it will ignore any special or process dot gain applied globally for that colour.

- Spectrophotometer - Choose a supported spectrophotometer to read colour values directly into the replace Colour Set.



Entering Colours with a Spectrophotometer.
HowTo

Select the device and select Activate. Once connection has been established you can measure colours and a new entry will be made into the tab selected for each reading. De-activate the Spectrophotometer when finished.

RIP

Overview

The RIP module allows you to configure how you get your Ripped jobs from your RIP into Blackmagic. Different RIPs store their files in different formats and in different locations. You must select the correct input filter and path to match your RIP as well as the network address and method of file transfer. The configuration is split into sections which are shown below. For a more detailed look at RIPs see Getting your files into the system.

Driver

This section allows you to select the input filter that you are going to use to poll and interpret the incoming file format. The driver must match the type of Ripped file that you have. The other sections of the RIP configuration may change depending on the RIP input filter selected.

- RIP Driver - choose the RIP driver (input filter) from the list of supported RIPs. The available drivers depend upon the bits that are enabled on the dongle.
- Custom Settings - Depending on the driver selected there may be some specific parameters that need to be setup to have a valid configuration. Use the Edit button to setup these parameters. See RIP Specific configuration.

Polling

This is where you configure how to poll the Ripped files. Polling is the method used to look for files. When you poll, Blackmagic looks in the specified location (defined under Paths) for files that match the RIP Driver selected. A list is compiled and sent back to Blackmagic for displaying in the RIPMonitor. It takes three (3) successful polls before a file is shown in the RIPMonitor. The files must be stable i.e. has not changed since the last poll. See Input of Files for more information. The options available are

- Enable Polling - Turn the polling on or off.
- Poll Interval - Configure how frequently you should poll the files.

Effects - The poll interval should be set according to your specific requirements. Setting the poll interval

too short can flood the network with polling requests (packets) causing it to slow down. Setting it too long can take a long time to show stable files ready for submission.



This value is used in conjunction with the Poll Service Refresh - See Input of files for more information on Polling.

- Fast Polling - This will automatically poll two (2) more times as soon as one (1) automatic poll has completed. i.e. it will not wait until it's next scheduled poll interval before it polls again.

Effects - Files can appear incomplete in the RIPMonitor if there has not been sufficient time between polls for a jobs complete set of plates to finish RIPPING.

Usage - It is recommended that this is only used when all plates of a job are available at one time or on static data i.e. data that does not change such as during a testing stage.

- Log Statistics - Log the polling statistics in the server log. The log message reports "started automatic poll on <date>" when polling starts and then "Completed automatic poll on <date>" when finished.

Usage - Determine how long it takes for one poll or confirm that polling is taking place.

- Ignore Mod Time - Ignores the modification time on the file. Useful for Harlequin RIPs that update the modification time on the file when moving the job between the held and active queues.



The first ever poll of a RIP always takes longer than subsequent polls i.e. once the initial list of jobs is built.

Connection

Specifies the method used for polling, The options are

- Method - Depending on the method of connection chosen the options available change. The connection methods and options are as follows
- Agent - The Serendipity Agent is installed on the RIP where the files are located. This is used for polling and submission of the Ripped files to Blackmagic.

- Hostname/IP - Enter the hostname or IP address of the RIP computer where the files are located and the agent is running.
- Localhost - This is used when the files appear locally to Blackmagic. This can be either on it's own disk or via a mounted volume through nfs or mapped drive with netbois.
- No options as this is local.
- FTP - Uses FTP to poll and transfer the files from the RIP to Blackmagic.
 - Hostname/IP - Enter the hostname or IP address of the RIP computer where the files are located. FTP must be running on the RIP computer.
 - Username - Enter a valid user name for logging into the RIP computer.
 - Password - Enter the password for the Username specified above.

File Transfer Priority

This specifies the priority to be used for transferring files from the RIP to Blackmagic. You can adjust from Lowest to Highest or anywhere in between.

Effects - Sometimes a high priority can effect the RIP performance especially on older RIPs. This can cause some problems such as RIPs pausing. If this happens reduce the priority.

Default - Highest - Always use this unless there are problems.

Paths

Specify the paths to the RIPed files that reside on your RIP. This may be a single path or multiple paths and can be made up of striped paths. The path structure is dependant upon the RIP Driver selected. See RIP Specific info for more information. The options available are shown below.

- New - Adds a new path or stripe path to the Paths field. Select this displays another window where you can type the path or Browse to locate the folder that contains the jobs.



The Browse option only works if the connection method has been specified and is valid.

- Delete - Deletes the selected paths.

- Delete All - Removes all the paths from the list.

Usage - Most RIP drivers use recursive polling i.e. they will poll down the directory structure into sub directories from the top level directory specified in Paths. The more sub directories that have to be searched for jobs the longer it takes. You should specify the path as far as possible to your files.

- Stripe Paths - Some RIPs place jobs on different drives but in the same location. They can add more drives to a RIP giving it a new mount point e.g E:/RIPjobs, F:/RIPjobs and G:/RIP-jobs. These all have a common path of RIPjobs but are “striped” across 3 drives. Therefore you would specify the drives (E:, F: and G:) in the Stripe paths and the Path (/RIPjobs) in Paths.

Usage - This is important for RIPs that share plates from single jobs across multiple drives e.g. Cyan and Magenta on E drive and Yellow and Black of the same job on F drive. If this is not set up as a stripe the plates will not be stitched together.

AutoProofing

Jobs can be submitted manually from the RIPMonitor as desired. Alternatively you can configure your RIP to have the jobs submitted automatically via the AutoProof facility. This way any new job that appears, is stable and meets the criteria specified will be submitted for processing. The options available are shown below.

- Enable AutoProofing - Turns the AutoProofing on or off.

Printing

Specifies how the jobs are to be printed. The options are

- Copies - Specify the number of copies to be printed when automatically submitted.

default - 0 (disabled)

- Use Pagesetup - Print to the selected Pagesetup.
- Pagesetup Pool - Print to the selected Pagesetup Pool.
- Choose - Select an existing Pagesetup or Pagesetup Pool. The chooser that displays also allows you to create a new one.

Usage - If you are autoproofing to one printer/ Pagesetup then choose Use Pagesetup and select the one you want. If you want to send the file to more than one queue, then choose Pagesetup Pool. These can be configured to share jobs across them or print to all of them. See “Pagesetup Pools” on page 66 for more info on Pools.

Criteria

You can select certain conditions that must exist before a job is automatically submitted. The options are

- Delay (minutes) - The length of time to wait to see if a job changes prior to submitting.

Usage - A job may change as other plates are RIPped and added to the job. A suitable amount of time needs to be specified to ensure a complete job is submitted.

- Minimum Plate Count - Specify a certain number of plates that must exist before a job is submitted for AutoProofing.
- Must Have - Select which process plates must exist in the job before AutoProofing.
- Filter - Select a Filter to use for auto-proofing. See “Regular Expression” on page 72.

Advanced

- Delete Jobs From RIP After AutoProofing - You can select to delete jobs after AutoProofing is successful.



This is only available when the jobs are local i.e. resident on the same computer that Blackmagic is running on. In this case the connection method is set to localhost.

Usage - This may be used when a temporary file is created such as when adding halftone dots to unscreened data. See Adding dots

- Hold after imaging - Places the job on hold in the Rendering queue. i.e. after imaging has completed successfully.

Job Filtering

This is only available when the RIP Driver is set to poll imposition RIPs. You can specify if AutoProofing should be carried out on All jobs or just imposed jobs.

Testing

Once the configuration is complete you can test that the parameters you entered are correct. The configuration must be saved before a test can be done. If it is not you will be prompted to save and test. A test poll check RIP connection, Path validity and job presence i.e. are there any jobs that match the RIP driver in the location specified. Messages appear in the window to alert you to problems or give you confirmation that the configuration is valid.



The configuration may be valid but there may not be any RIPed jobs in the path specified. Testing will alert you to this. For a full listing of error messages see Errors.

Signature Group

Overview

The Signature Group gives you the ability to build groups of signatures which are used for de-imposition, i.e. taking an imposed file and splitting it into smaller files. These are normally either as single pages or 2ups but any size can be created. The signatures can either be imported or created manually giving parameters such as sheet size and page size etc. (See HowTo “Create a New Signature manually” on page 87). Files can then be selected and submitted for de-imposition as needed or you can create a setup where files are de-imposed automatically. There are many options available for the Signature Group and are shown below.

The layout of the interface has a toolbar along the top with various options (detailed below). On the left there is a tabbed area that switches between the “Signatures” for a given group and “Pages” which allows the configuration of the individual signature. You can switch between the signatures and pages by either selecting the tab or by clicking on a page in the signature (for Pages options) or the background (sheet indicated by the white area) for the signature list.

Tool Bar

The Tool Bar has a number of options. Some are display options and some are actions. These options are also accessible via the contextual menu (right click). You can display or hide the tool bar by clicking on the spanner icon. You can set the options that appear in the tool bar by right clicking in the tool bar area and choosing your preferred options or selecting the “Configure toolbar”. This will present you with a chooser showing available items on the left and displayed items on the right. Either double click or drag the options between the two list. Alternatively you can select items and click the arrow keys. Re-order the buttons on the list to your preferred display order. The available options on the toolbar are as follows

- Group - Groups two or more pages together. Pages must be the same size and alignment. The Group button is only available when valid pages are selected.
- Ungroup - Ungroups a group of pages. Only available when a group is selected.
- Suppress Pages - Suppress the selected page or pages (marks it not for print).

- Auto Paginate - Automatically allocates page numbers to the signature. This will include any page that is currently suppressed.
- Offset Page Number - Offsets the page numbers by the desired amount. A pop up window allows you to enter the offset value. This then adds that amount to the each page number.
- Edit Page Number - Edits the page number of those selected. Tab moves to the next selected page. The page numbers can also be edited by clicking on the page.
- Pair Pages - Automatically pairs the pages along the long sides. The pages must match i.e. the headers must be in the same position and they must be joined i.e. no gap. If there is a gap then the manual pair option must be used.
- Pair Pages Horizontally - Pairs pages in the horizontal direction.
- Pair pages Vertically - Pairs pages in the vertical direction.



Pages must align and have the same orientation for pairing to be successful.

- Rotate selected signatures - Rotates the selected signatures by the amount chosen. The options are
 - 90 Degrees Clockwise
 - 90 Degrees Counter Clockwise
 - 180 Degrees
- Rename Signatures - This allows you to rename signatures. Selecting this displays a rename box allowing you to search for and replace names.
 - Find - Enter the characters to find in the list.
 - Replace With - Enter the text to insert in place of the characters found. You can use any valid characters including spaces. If nothing is entered then the characters found are deleted if one of the rename options are selected.
 - Ignore Case - Choose whether your match is case sensitive.
 - Wrap Around - Continue at the top of the list when the bottom is reached.

- Rename All - Rename all items that are found.
- Rename Selected - Only rename the selected signatures if the characters are found.
- Rename Current - Rename the currently selected signature if the characters are found. If more than one is selected then the first one in the list is checked for a match and renamed if true.
- Find Previous - Searches backwards.
- Find Next - Searches forwards.
- Prefix With/Append - These are two more options available from the pull down menu in place of Find that allow you to add characters before or after the names.
- Import Signatures - You can import signatures made by other applications. See HowTo “Import a signature” on page 87 The available types are
 - DynaStrip - Imports signatures created with DynaStrip. Selecting this displays a file chooser allowing you to select one or more signatures. The file names are usually named with a sheet number and an extension of .dsf - e.g. myjob (Sheet 00001).dsf
 - Preps - Imports signatures created with Preps. Selecting this displays a file chooser allowing you to select one or more signatures. The file types are Prep Templates.
 - Krause - Imports signature from Krause imposition package. Selecting this displays a chooser allowing you to select one of more signatures. The filenames usually end in a number such as jobname.001.
 - JDF - Imports any JDF based signature. These include signastation. Selecting this displays a chooser allowing you to select one or more signature files. The file types have a .jdf extension.
 - Facilis - Imports Facilis signatures. Selecting this displays a chooser allowing you to select one or more signature files. The file types are named with a .dai extension.
- Selective Import - Tick the box to select which signatures out of a group that you wish to import. You can also perform various tasks on them at import time. Selecting this option prior to choosing the type of signature to import will display further options. See HowTo “Use selective import” on page 87 These are
 - Inclusive Page Grouping - This option attempts to group pages that differ by very

small amounts. Grouping allows for the pairing function to work.

- Rotation - Choose to rotate the signatures during import.
- Offset Page Numbers - Offset the page numbers of the those signatures imported by a number.

Display Options

There are two different display options

- Top Align - Displays the configuration section along the top of the of the display area and the signatures along the bottom.
- Left Align - Displays the configuration section along the left of the of the display area and the signatures along the right.

Usage - The view is a personal preference and should be used in conjunction with the window split option to suit your display.

- Import Language Encoding - This allows you to select the appropriate language encoding for the signatures so that the names can be displayed correctly in the native language.

Signatures

With the Signatures tab selected all the signatures for the group are shown. Below the list are the options that apply to the signature. Some of these options are for individual signatures and some will apply to all selected. If more than one signature is selected and a parameter is displayed in bold (such as width) it means that the parameter differs between the selected signatures.

You can also multi-select the signatures and change some page parameters by clicking on the Page tab. The available options are then displayed. Below details the options for the signatures. See “Pages” on page 86 for the pages configuration information.

- New - Creates a new Untitled signature.
- Delete - Removes the selected signatures from the list.
- Duplicate - Makes a copy of the selected signatures.

Press Sheet

Enter the dimensions of the press sheet. The options are

- Width - Width of Press Sheet
- Height - Height of Press Sheet.
- AutoFit - Changes the Press Sheet size so that the pages fit.

Plate Options

Turn the plate options on or off by selecting the click box. The plate settings are as follows

- Plate Width - Enter the width of the plate.
- Plate Height - Enter the height of the plate.
- Centre Offset - Enter the value to Offset the centre by. This is dependant upon the gripper position.
- Gripper size - Specify a value for the Gripper.
- Position - Choose where the gripper is positioned.



The Plate Width and Height will alter the Press Sheet size if the plate size is larger. If the plate size is smaller then the Press Sheet size is not affected.

Pages

From here you configure the attributes of the pages that are on the press sheet. This is split into two sections describe below

Grid Attributes

- X and Y position - This sets the position of the selected group or page and is in respect to the top left of the press sheet to the top left of the page or group.
- Page Size - Select the size of the single page selected from one of the pre-set page sizes or choose Custom.
- Page Width - Enter the width of the single page selected. The pre-set page sizes automatically fill this in.
- Page Height - Enter the height of the single page selected. The pre-set page sizes automatically fill this in.
- Orientation - Select the orientation of the selected page between Portrait or Landscape.
- Columns - Enter the number of columns for the signature.

- Rows - Enter the number of rows for the signature.
- Gutter X and Y - Enter the size of the gutter for the signature.



TIP If you select a gap first then the value is applied to the selected only. If you wish to apply a value to either All, Even or None then you need to select it from the put-down menu first, then enter the value and press enter for the value to be applied to the selection.

- Delete - Deletes the selected pages or groups.
- Duplicate - Duplicates the selected page or group. This is positioned at top left (X=0, Y=0).
- New/Place - Creates a new page or group. Selecting this changes the button to be "Place". You then enter the page attributes as desired and press place to position the page or group.



TIP If you change your mind press the Escape key to cancel the place.

Page Attributes

- Number - Enter the number of the pages selected.
- Top Bleed - Enter the amount of top bleed to apply to the selected pages.
- Bottom Bleed - Enter the amount of bottom bleed to apply to the selected pages.
- Left Bleed - Enter the amount of left bleed to apply to the selected pages.
- Right Bleed - Enter the amount of right bleed to apply to the selected pages.
- Page head - You can select the position for the head of the currently selected pages. As you choose the diagram shows the change. The page head is indicated by a line and folded corner. Choose between
 - Page Head Up
 - Page Head Down
 - Page Head Left
 - Page Head Right



Create a New Signature manually

HowTo

1. Create a new Signature Group and enter a name for the group.
2. Select the Signatures tab and choose “New” to create a new signature. Enter the name for the signature.
3. Select the Pages tab (or click on the page).
4. Enter the values as desired for the grid and page attributes.
5. Paginate the pages as desired. Either manually enter the page numbers or select all pages and choose Auto Paginate.
6. Select Signatures tab and choose Autofit or enter the desired values for the press sheet.
7. Save.

You can now select files for de-imposition and choose the new signature to use to de-impose. You can also select the signature in the Pagesetup for auto de-imposition. Any jobs that are submitted to the Pagesetup and match one of the Press Sheet Sizes of the Signature Group will use the signature for de-imposition.



The tolerances of press sheet size for matching signatures in the Pagesetup is less than, or equal to 1 inch in width and height. If no signature is within these tolerances then job passes through without being de-imposed.



Import a signature

HowTo

1. Create a new Signature group.
2. Select the import button for your signature.
3. Navigate to locate your signature files. Select one or more files to import and choose Open.
4. Make adjustments as necessary to the signature and save.

Below is a list of adjustments and tips on how to achieve them.

1. Rotate all the signatures 90 degrees.

- Select the Signature Tab
- Select all the signatures

- Choose 90 degrees rotation
- save

2. Adjust the plate attributes to all signatures.
 - Select the Signatures Tab
 - Select all the signatures
 - Choose “Use Plate” and enter the values as desired.
 - Save
3. Change the head position on all pages on all signatures.
 - Select the Signatures Tab.
 - Select all the signatures.
 - Select the page head in the desired direction.
 - Save
4. Pair all pages horizontally on all signatures.
 - Ensure all pages have the same page head direction and size that you wish to pair.
 - Select the Signatures Tab.
 - Select all the signatures.
 - Select Pair Pages Horizontally.
 - Save



Use selective import

HowTo

1. Ensure the “Selective Import” tick box is checked.
2. Choose the signature import button that matches the type you have e.g. Dynastrip, Preps etc.
3. Use the browser to locate your signatures. More than one can be selected simultaneously. Select open when ready.
4. Select a single signature from the list to view it. Select multiple signatures to import. Use Shift key for group selection or control key for selective selection. Or Apple+A (control+A) for everything.
5. Select the attributes to apply to the signatures during the import stage. e.g. If you want to rotate all the pages by 90 degrees, select it from the menu.
6. Choose OK to import the selected signatures.
7. Repeat as needed.

Special Colour Set

Overview

Serendipity Blackmagic uses Special Colour Sets to identify and match colours when jobs are polled and processed. Colours can be created internally or imported from popular applications such as Adobe Photoshop. Multiple sets can be built and used at any time. You can create colours in CMYK or LAB space or read values directly into the system with an on-line spectrophotometer. The colours property can also be set and an individual dot gain curve assigned if desired. With a colour calibrated monitor (ICC profile saved into the system. See “System Settings” on page 114) an accurate representation of each colour in the set is shown.

The window is split into two sections. The right shows a list of the colours in the special set. The properties for each colour are also shown. The left section allows you to adjust those properties. Selecting a colour from the list loads its attributes into the colour adjustment section allowing you to alter the values as desired.

Toolbar

The toolbar has a number of options available. Clicking the spanner icon reveals/hides the Toolbar. You can customise the view by right clicking in the toolbar area and selecting which options you show. All the options are available from the context (right click) menu on the colour list. The options are shown below.

- New Colour - Creates a new untitled colour in the list. You can then adjust the colour using the sliders on the left and changing its properties with the paint mode selector. Select the name (untitled) of the colour to change it.
 - Delete Colours - Deletes the selected colours. You can also use the delete key.
 - Duplicate Colours - Makes a copy of the selected colours.
 - Add Colours From Library - Allows you to select one or more colours from any other Special Colour Set created in Blackmagic.
 - Import Colours From Files - Allows you to import colours from popular desktop applications or previously exported colours from Blackmagic.
 - Export Colours To File - Export the colours to a file. You will be prompted for the file name and destination of the file.
-  If the set contains a mix of CMYK and LAB colours you will be prompted to choose to save the CMYK colours or the LAB colours. These cannot be saved in the same file.
- Rename Colours - Allows you to rename one or more colours. This is done using a Find and Replace search tool. Selecting will display another window with various options shown below.
 - Find - Enter the characters to find in the list.
 - Replace With - Enter the text to insert in place of the characters found. You can use any valid characters including spaces. If nothing is entered then the characters found are deleted if one of the rename options are selected.
 - Ignore Case - Choose whether your match is case sensitive.
 - Wrap Around - Continue at the top of the list when the bottom is reached.
 - Rename All - Rename all items that are found.
 - Rename Selected - Only rename the selected colours if the characters are found.
 - Rename Current - Rename the currently selected colour if the characters are found. If more than one is selected then the first one in the list is checked for a match and renamed if true.
 - Find Previous - Searches backwards.
 - Find Next - Searches forwards.
 - Prefix With/Append - These are two more options available from the pull down menu in place of Find that allow you to add characters before or after the names.
- Usage - You can use this for fast renaming of all your specials if for example they are named Pantone XXX and you want them to have a Pantone XXX CVC, you can use Append with CVC and Rename All or Rename Selected.

Column Headings

The list of colours has a series of columns that give information about the properties of the plate. These column headers can be turned on or off as desired. Right click in the header area and choose the preferred headings. Change the order of the headers by selecting and dragging to your preferred position. The headers available are

- Colour - Gives a visual representation of the colour.
- Name - The plate name. This is the name that is used to match the colours with.
- Space - The colour space of the plate.
- Mode - The Paint mode of the colour i.e. Overprint, Knockout, Primer or Opaque.
- Tint - The tint or intensity of the colour.
- DotGain Curve - The name of the dot gain curve applied to the plate (if any).

Colour Adjustment

This section allows you to view and adjust the colour values and plate properties. The name of the colour selected is shown at the top. A window displays the Original colour and the Adjusted or Modified colour. With an accurate ICC profile selected in the Client settings the colour represented is correct. The available options are

- Colour Space - Choose between LAB or CMYK. The sliders change accordingly allowing you to make your adjustments.
- Paint Mode - Choose the paint mode for the Colour. The choices are
 - Overprint
 - Knockout
 - Primer
 - Opaque

The diagram changes to give you a visual representation of the paint mode. When Opaque is selected a slider becomes available allowing you to choose the opacity of the colour.

- Tint - Adjust the intensity of the colour by adjusting the slider or entering a tint value in the box.
- DotGain Curve - Choose a dot gain curve to apply to the colour.



Any dot gain applied to a colour has priority over the system dot gains i.e. it will ignore any special or process dot gain curve applied globally for that colour.

- Spectrophotometer - Choose a supported spectrophotometer to read colour values directly into the Special Colour Set.



HowTo

Read colours in from spectrophotometer.

Select the device and choose Activate. Once connection has been established you can measure colours and a new untitled colour is created in the list. Select the name to change it to the correct name of the colour. De-activate the Spectrophotometer when finished.

Applications

The image displays several overlapping application windows from the Serendipity Blackmagic V3 software suite:

- ClusterManager**: Shows system information for a master node (Serendipity Blackmagic, Version 3.0) and a list of slave nodes with their IP addresses, names, speeds, platforms, and CPU counts.
- Spectrophotometer**: Displays color data for a Gretag Eye-One Rev 1.06, including L*a*b* values (L: 41.039, a: 20.408, b: -58.266) and a list of color swatches with their names, spaces, modes, and ΔE values.
- Densitometer**: Shows a 'Last Measurement' of 1.522 for a Magenta color, with associated C, Y, and K values (C: 0.161, Y: 0.582, K: 0.637). It also includes a 'Yule Nielsen Number' of 2.0 and a table of color density data.
- Chatting with "Cane Toad"**: A chat window showing a conversation between 'Elvis' and 'Cane Toad' dated Friday August 13 2004 10:40:39.
- Color Density Table**: A detailed table of color density data for various colors, including columns for Name, Colour, Density, Cd, Md, Yd, and Kd.
- Advance Options**: A panel for adjusting Yule Nielsen numbers and Maximum Densities for different colors (Black, Cyan, Magenta, Yellow, Orange, Green).

Soft Proof

Overview

The SoftProof Tool is used for previewing jobs in the system. You can preview the Imaged data or the Rendered data of a job. When previewing the Imaged data you see all the plates of the job at the full output resolution. The rendered preview is shown at 150dpi and only shows the plates of the output colour space. The plates can be turned on and off or replaced with any colour from the Special Colour libraries. You can also replace all plates with a complete replace colour set. You can apply effects such as zoom in or out, rotate or mirror. You can also export CIP3 data to a file. With an accurate ICC profile selected in the system settings the preview will be colour correct.

Starting the SoftProof Tool

There are two methods to start the SoftProof Tool.

1. From the Application menu of the Serendipity Client. Choose SoftProof.
2. From the QueueManager by selecting a job and choosing View Imaged or View Rendered.

Once the SoftProof Tool is running there are many available options. These are detailed below.

View Options

There are many tools to manipulate the image which are available from the “View” Menu or by right clicking in the image area. The Options are

- Rotate 90 CW - Rotates the image 90 degrees clockwise.
- Rotate 180 - Rotates the image 180 degree.
- Rotate 90 CCW - Rotates the image 90 degree counter clockwise.
- Zoom in/out - Zooms in or out of the image.
- Mirror - Mirrors the image.
- Negative - Negates the image.
- Default zoom level - Set the default zoom level for future jobs opened in the SoftProof.

 The default is 0 which means do not change the factor and open at 100%. The level is set either positive (greater than 100%) or negative (less than 100%) as a factor from 100%. So a default value of 2 will open the subsequent

SoftProof windows at 300% (100% +100% + 100% or 3 x 100). Likewise a factor of -2 will open at 33.33% (3 x 33.33%).

- Default rotation - Set the default orientation for future jobs opened in the SoftProof. Choose between 90 CW, 180 or 90 CCW.
- Job Info - Displays information about the job and how it was processed.
- Loupe - Displays a Virtual Loupe to view the preview at 100% in the loupe square. You can change between a bigger loupe and smaller loupe by right clicking inside the loupe area.
- Page Boundary - This places a red line around the page area of the job. This is viewable when the Soft Proof window is large and image is reduced so that you can see where the page is.

Signatures

- Reverse page viewing - Will display the reverse side of a page through the page currently loaded. Available when viewing a page as part of a publication. Reverse page must be processed.
- Transparency for reverse page viewing - Enter a level of transparency for the backpage to come through the front. Changing the value while a page is loaded dynamically updates the view.
- Signature Overlay - Overlay the signature used to de-impose a job. Available only if job has been de-imposed.
- Thumbnail - Displays a Thumbnail of pages in the Pages Pane when viewing a publication.

 The Pages Pane is only displayed when you are viewing a page from a publication. The Thumbnail shows the page where the mouse pointer is currently over. The Page Pane is the same as that used in the FlipBook.

- Edit Signature - Allows you to make changes to the signature without closing the SoftProof.



TIP

You can make changes to the Signature and view the fitting in the SoftProof window using Signature Overlay. Then when you have it correct you can release the imaged file

to render and de-impose with the edited signature. Note that there is a limit to the accuracy of the SoftProof view when compared to the printed output.

File Menu

- Load Image - Loads an image file direct into the SoftProof. Image file types supported are
 - Canon RAW format
 - JPEG
 - PNG
 - PPM
 - Serendipity Blackmagic Image
 - Tiff
- Save Serendipity Blackmagic Image - Saves the preview as a BM Image file. This can be submitted or placed in a hot folder or drop-zone.
- TWAIN Acquire - Uses connected scanner to import direct into the SoftProof Application.

 This is only available from the menu under File. The scanner must be connected and operating normally for this to work and uses the manufacturers driver to capture. Please consult the scanners user guide for more information.

- Export - Allows you export data from the SoftProof Tool. The available formats are
 - CIP3 (Version 3.0) - Exports job information to a file in CIP3 format - Version 3.0.
 - CIP3 (Version 2.1) - Exports job information to a file in CIP3 format - Version 2.1
 - Postscript (separated) - Exports the current job as a separated PS file.
 - Tiff Multichannel - Exports the current file as a multichannel Tiff.
- Submit - Submits the current job to a Pagesetup with any current changes. This re-images and re-renders the file.

 When submitting the image back to be processed again with the relevant changes the current image resolution is reset. Therefore if you have restricted the resolution in the System Settings this resolution will be submitted. For example the default rendered preview resolution is 180 dpi and the default imaged preview is Pagesetup output resolution. It is therefore recommended that you use the imaged preview if you are cropping and re-submitting and leave the rendered preview for low resolution soft proofing. See “System Settings” on

page 114 for more information on preview resolutions.

- Channel Viewer - Shows or hides the Channel viewer. See Channel Viewer below.
- Plate Colours - On the context menu you will see the plate colours that are associated with the job. These can be turned on or off as desired by selecting them. This is also available from the Channel Viewer.



TIP

You can drag and drop the plates in the channel viewer into any order you prefer and re-submit the file for processing in the new order.



Note: Plate colours cannot be changed or re-ordered if the colour space is RGB

Additional Menu View Options.

- Full Screen - Changes between full screen mode and window mode.
- Show All - Shows the whole job in the window.
- Show Actual Pixels - One pixel of the screen is equal to one pixel of the job. This is shown at 100%.
- Show Approximate Print Size - Shows an approximation of the actual size of the job.



This is more accurate when viewing the Imaged Preview (providing the preview resolution has not been restricted to a low resolution in the System Settings).

Windows

There are a couple of utility windows that are stand alone for job manipulation. These are

- Navigator - This window shows a thumbnail of the job. There is a box on the thumbnail which gives you the location of the main image window. Select Large Navigator to display a larger thumbnail window for easier navigation.



You can also move around the job by selecting it in the main window and dragging it in the desired direction.

- Channel Viewer - Shows all the channels of the job. The window displays the following.
 - Name - The plate name. This can be turned on or off using the tick box next to the name.
 - Value - The percentage of that colour at the point of the colour selector. This is the cross point of the hand cursor displayed on the main image window. Total ink displays the total amount of ink at the point of the colour selector i.e. the sum of all the plates percentages.
 - Mode - The Paint Mode of the colour as defined in the Special Colour Set or Replace Colour Set.
 - Tint - The intensity or tint value of the colour.



You can change the tint value of the colour by double clicking on the value in the channel viewer and entering a new value. This changes it for the instance you are viewing the job and for a re-submit of the job.

- default - If it is not defined then the default is overprint.
- DotGain - The name of the DotGain curve applied to the colour. This is blank if no DotGain is applied.
- Search - At the bottom of the Channel Viewer there is a search or filter field. Enter a text string and items in the Channel Viewer that match are displayed.

Contextual Menu Items

By right clicking on the Channel Viewer a contextual menu appears with some additional options. These are

- Choose Plate Colour - Select a plate colour from a Special Colour Set. This is only available if you right click on a colour. You can also double click a colour to replace it.
- Choose Paper Colour - Select a special colour from the Special Colour Set to use to simulate the paper colour.



Once the Paper Colour is selected it is remembered next time the SoftProof is used. The Paper Colour will affect all colours. In order to not have the Paper Colour displayed you must explicitly set to None.

- Apply a Replace Colour Set - Select a Replace Colour Set to replace all colours with.
- Revert All Plates - Changes all the plates back to their original values.

Tools

There are four tool choices

- Zoom - Allows you to zoom in or zoom out. Clicking the mouse zooms in twice the current percentage factor. Holding the shift key and clicking zooms out to half the current percentage factor. You can also click and drag over a certain area to zoom in. This works in the both the main window and the navigator.
- Crop - Allows you to crop an image and re-submit it. See “Crop and image and re-submit it.” on page 95
- Measure - Allows you to take a measurement on the image. The cursor displays as a rule. Use the shift key to draw straight lines.
- Pan - Allows you to navigate around the image. The cursor displays as a hand.



You can crop in either the main window or in the thumbnail window. It can be useful to make a rough crop in the thumbnail window first and the fine tune your crop in the main window with a smaller image size. You can move to the pan tool temporarily by holding the space bar. After panning release the space bar to revert back to the previously selected tool.



Measure on an image

HowTo

1. Select Measure from the Tools Menu.
2. Click on the image at the starting point.
3. Hold the mouse button and drag to the end point.
4. Hold the Shift Key while dragging to draw straight lines in either a horizontal or vertical direction.
5. Release the button to display the distance from the start point to the end point.



Apply a Blue Line to show traps.

HowTo

1. Load an Image by selecting a job in the QueueManager and choosing “View Imaged”
2. Right click in the Channel Viewer and select “Apply Replace Colour Set”.
3. Choose “Blue Line” from selection on the left and click OK.
4. Right click and select Revert All Plates to revert to the original view.



Any changes here are only changes to the preview. The job is not altered in any way.



HowTo

Crop and image and re-submit it.

1. Open an image in the SoftProof.*
2. Choose Crop from the Tools menu option
3. Click on the image in the main window or thumbnail and drag to draw a rectangle
4. Position the rectangle by dragging it to where you want it. Resize from the corners as desired. (Resizing a cropped area is only available in the main window.)
5. Press the Enter key and the image will crop. Alternatively you can double click inside the rectangle or right click and choose “crop” from the contextual menu.
6. To crop the area you are currently viewing in the main window simply have the crop tool selected, move to the thumbnail window and press the Enter key. This allows you to zoom into a particular area and crop what you are viewing.
7. To cancel out of a crop press the escape key or right click and choose “cancel” from the contextual menu.
8. Once cropped, right click on the image and choose “Submit”
9. Select the Pagesetup you wish to send the file to and press the submit button.



* Note: The resolution of the preview determines the input resolution of the submitted image. Therefore if you view the rendered file and you have the Print Preview Resolution in System Setting set to say 180dpi then this will be the resolution of the file submitted again. It therefore recommended for high res output that you

view the Imaged Preview and crop that. This also needs to be full imaged resolution. See “Client Settings” on page 114 for more info on Preview resolutions.

Densitometer

Overview

The Densitometer Application allows you to take readings of densities with any of the supported on-line devices and display them on screen. When measuring a colour, the densities of all four colours are read each time. i.e. the CMYK content of the measured patch. A large display area shows the colour measured with the values of the other three colours to the right. You can view percentage dot area and the patch colour. The values can be recorded and saved to a file if desired. The available options are shown below.

Measure Targets

This is available from the menu bar or via the context menu (right click) on the application window. This allows you to measure the solid densities for the process colours and also measure the paper white. With these values stored the colour percentage can be calculated and displayed. You can measure or update an individual density or measure all targets.



To read percentage tint values of any plate you must read the paper white and the solid density value for that colour.

- Delete - Deletes the selected readings from the list. You can also use the keyboard Delete key.
- Delete All - Clears all the reading in the list.



The reference values remain stored while the application is running.

- Font Options - Set the text size to the preferred size.

Export

You can export the values from the list to a file. The options available are

- All - Saves all entries on the list.
- Selected - Just save the entries from the list that are selected.

Selecting either of the these options displays a window allowing you to choose the values that are saving. The choices are

- Name - Save the name of the colour.

- Colour Density - The highest density reading regardless of colour i.e. the highest value read of either C,M,Y or K.
- Cyan/Magenta/Yellow/Black density - The density reading of the chosen colour. i.e. if cyan is selected then the cyan density for each reading taken. This is the value displayed in Cd column of the list.
- Colour Percentage - The percentage reading of the highest density read as displayed in the Dot% column.
- Cyan/Magenta/Yellow/Black Percentage - The percentage reading of the chosen colour i.e. if cyan is selected then the percentage reading of cyan for each reading as displayed by the C% column.



The percentage values must be present for the values to be exported (see Measure Targets above). If they are not read then the file will show a -1.0% value in place of the reading.

- Order value - Choose whether to export the file in CMYK of KCMY order.
- Separate Values With - Choose whether to separate the values with a tab character or a space.
- Cancel - Cancels the Export action.
- Export - Displays a file chooser allowing you to enter a name and select a location where the file will be saved.

Miscellaneous options

- Yule Nielsen Number - Enter the YN number for the paper you are reading if you know it.

default - 2

- Densitometer - Choose one of the supported densitometers or spectrophotometers from the available list.
- Instrument Density Standard - Select your desired density standard from the available list. See “Supported Density Standards” on page 97 for more information.
- Activate/Deactivate - Connects or disconnects to the chosen device.

- Add - Adds the measured values to the list. This appears after the densitometer has connected without error.

 After selecting a densitometer from the list and choosing activate there may be messages reported from the device which will display in the status field. This field is shown when the device connects without error. Follow any message when prompted. E.g Measure cyan solid.

Colour List

This is a list of readings taken if the Add is enabled. Each reading is appended to the list and the values that are measured are displayed. The columns can be resized or reordered as desired by dragging the header to the preferred position. The columns are

- Name - Name of the colour read - Defaults to Untitled but can be changed by selecting the name and entering a new one.
- Colour - Shows the dominant colour read. i.e. the one with the highest density value.

 This may not be the colour you perceive it is, but the contents that make up that colour are recorded and the colour is calculated and shown.

- Density - The density value for the colour. This is the highest density read from C,M,Y and K. i.e. it shows the density of the colour stated in the “Colour” column.
- Cd/Md/Yd/Kd - The C,M,Y and K densities of the colour read.
- Dot% - The percentage dot of the colour shown in the “Colour” column.
- C%/M%/Y%/K% - The C,M,Y and K percentage values for the colour measured.

 If any of the % columns are blank then the reference paper white or solid density for that colour have not been read.

Usage: The Densitometer Application is a utility that allows you to use your densitometer or spectrophotometer that does not have a display to read values. This can be as a one off reading to compare densities or you may want to read values and export them for plotting on a graph. There is no requirement to use this for the normal operation of Serendipity Blackmagic.



Make a density measurement

HowTo

1. Connect the device to the computer where the client is running.
2. Choose the device from the list, choose your preferred density standard and select Activate.

 Note: The density standard can be changed at any time during the process. You need to give the instrument time to change. The status line will instruct you when you can read the next measurement. See below for more information.

3. Follow any instructions shown on the status window at the bottom.
4. Measure the Paper White and Solid densities of the process colours where you are taking your measurements from.
5. Select “Add” check box to append the readings to the list.
6. Take your measurements.
7. Export the values to a file if desired.
8. Turn Off the measurement device.

Table 1: Supported Density Standards

Instrument	Density Standard - Status				
	A	E	I	T	default
DTP41	✓	✓	✓	✓	✓
DTP34	✗	✗	✗	✗	✓
DTP22	✓	✓	✓	✓	✓
DTP20	✓	✓	✓	✓	✓
Spectrolino	✓	✗	✗	✓	✓
EyeOne	✓	✗	✗	✓	✓

 Note: Not all instruments support all density standards. This table is a not a complete list. Consult your instrument operators manual for more information.

Spectrophotometer

Overview

The Spectrophotometer application allows you to measure colours with a spectrophotometer and view the accuracy of the measured value against an imported value when mapped through a selected ICC profile. You can select special sets, a match ICC profile and choose one of the supported on-line spectrophotometers to measure a delta E reading amongst other colour models.

The window is split into two sections. The right side allows you to import and view a Special Set which is used as the comparison base. The left side displays the measured values. Selecting a particular measured value then matches the closest colour of the imported set, giving it relative Delta E values. These can also be filtered to only show the closest matches for better viewing. The options available are as follows.

- Load Set - Select a special set to load. This is the set you want to use to compare measured values with. Choose from any of the special colour sets you have created.
- Match ICC - Select a match ICC profile.
- Rendering Intent - Choose the rendering intent.
- Spectrophotometer - Select a spectrophotometer from the supported devices.
- Activate - Connect to the selected Spectrophotometer.



Once you connect to the device the pull down list of devices changes to show you any status messages from the device and the values that are measured.

- Turn Off - The activate button changes to Turn Off once successful connection to a device has been achieved.
- Add - Select this to append to the list for each reading. If this is not selected then the currently selected colour is updated. This is available after the device has connected successfully.
- ΔE - Select the value of delta E that you wish to display. This is used in conjunction with the Show all swatches option. See below.

- Show all swatches - Select this if you want to view all swatches. By un-selecting this only those swatches that are below or equal to the delta E value entered are displayed.
- Export - This is a menu option to allow you to export the measured values into a file. The choices are
 - All - Saves all the measured values to a file.
 - Selected - Saves only those entries that are highlighted.

By selecting either of these two options you are presented with a dialogue box asking you to choose the format. The options are

- Lab - Exports just the Lab values.
- xyz - Exports just the xyz values.
- Lab xyz - Exports the Lab values followed by the xyz values on the same line.
- xyz Lab - Exports the xyz values followed by the Lab values on the same line.
- Separate Values With - Choose if the values are to be separated with spaces or Tabs.

Column Headers

Both the lists (loaded set and measured values) have various column headers. These can be used to sort values by clicking in the header. The columns can be turned on or off by right clicking in the header area and selecting the desired columns to display or hide. You can re-order the columns by selecting them and dragging to the desired position along the headers. The columns headers are detailed below.

- Colour - Gives a visual representation of the value loaded or measured. Select an appropriate ICC profile for the monitor under the System settings for an accurate view.
- Name - The name of the colour. You can change the name of the measured value by highlighting the name and entering a new one.
- Space - The colour space of the colour.
- Mode - The mode of the colour. This can be either overprint, knockout, primer or opaque.
- DotGain Curve - Displays the name of any dotgain Curve that has been applied to the colour.

- Delta E - The calculated delta E difference between the selected colour from the measured list and the colours in the imported list.
- CEI94, CMC(1:1), CMC(2:1), Delta L, Delta a, Delta b - Various colour models showing the calculated difference between the selected colour from the measured list and the colours in the imported list.



HowTo

1. Load a special set. If the ones that you want are not available then you can create one with the special colour set module. See “Special Colour Set” on page 88.
2. Select an ICC profile. This should match the ICC profile you are using in your Pagesetup.
3. Choose the rendering intent that you are using in your Pagesetup.
4. Select the spectrophotometer that you have connected.
5. Choose Activate and follow the instructions in the status messages.
6. Measure your values.

As you measure you will see the values change on the loaded list of colours. If you select the delta E column heading the values are shown in ascending or descending order of Delta E. Un-selecting the “Show all swatches” check box and entering 10 in the delta E box will only display the values that are below 10 Delta E.

You can drag and drop Lab colours from any special colour set or replace colour set on to the measured list (left). You can also drag any colours measured into any special set or replace set.

Lineariser

Overview

The Lineariser Application creates a linearisation curve of your output device and applies it to your Pagesetup. It is the third step in the calibration process and brings your output device to a known state i.e. Linear. This means that a 50% cyan will print out at 50% etc. It achieves this by printing a step wedge chart on the output device in the colour space specified by the Pagesetup. This is then measured with an on-line densitometer and the resultant correction curve saved. After this stage ICC profiles can be created and applied to the Pagesetup for accurate colour. If the printer varies with ink batches or head wear then a quick re-linearisation process is all that is required to get back to the same linear state that the ICC profiles were created with initially. Therefore the original ICC profiles can be re-applied to achieve the same colour output.

When you first start the Lineariser you will see two windows. One is the actual Lineariser window which is at the back and the other is a Lineariser Wizard. The wizard takes you through the step by step process from printing the chart to making the measurement. During the linearisation process any other colour management that is applied is temporarily disabled except for the Paper Profile. See the “Calibration Guide” on page 118 for more information on creating a colour managed path. The options for the Lineariser and Wizard are detailed below.



You must create your Pagesetup before the linearisation process.

Wizard

Launch the Lineariser from the Application Menu. This will start the Linearisation Wizard and place it on top of all the other windows. The wizard window is split into two sections. On the left there is a list of Pagesetups that are configured on the server. The right side shows a graph that displays a Linearisation curve if one is currently applied to the selected Pagesetup. On the far right is a list of Pagesetups that use the curve. If you are updating a curve that is used by more than one Pagesetup you can see which ones will be affected. The description below will take you through the Wizard step by step explaining the options.

First Step

From the first window you must select a Pagesetup to linearise from the list of Pagesetups. Select Next to move to the next step in the wizard. This is only available once a Pagesetup is selected. Choose Cancel to exit from the linearisation process.

Second Step

The second stage is to select the an instrument from the supported devices on the left list to match the device you have. Then select the instrument density standard you wish to use. See “Supported Density Standards” on page 97 in Densitometer for more information.



If you do not have one of the devices you can still linearise by selecting Manual Entry providing you can measure density values. This will allow you enter values via the keyboard.

Selecting the Manual Entry will exit from the Wizard and display the Lineariser window. See “Lineariser window” on page 101 below if you select this option.

Once you have selected your device you need to select “Print Chart”. The appropriate chart will be submitted to the Pagesetup you selected in the first step.

Once the chart has printed and had a short time to stabilise you can select Next to move to the final step and measure the chart. Choose Back to take you to the previous screen so you can make a change.

Final Step

The Final stage takes you to the measuring window. It connects to the instrument that you selected and prepares it for reading. At the bottom of the window is a status field which tells you what to do. You can move back to a previous stage by selecting the Back button. Once you have read each strip you can choose the Submit button to save the measurements and apply them automatically to the Pagesetup you are linearising. You can re-read a strip at any time by selecting the strip and following the messages in the status window. To exit from the linearisation process choose the Cancel button.



If you are using the Xrite DTP20 Pulse then there are two methods you can use. Either have the device connected while making measurements in the normal way. Or measurements can be taken off line and then uploaded later to the client. See “Using the Xrite DTP20 Pulse” on page 136 for more information on using this device with the Lineariser.

If you selected “from text file” in the instruments list you will be presented with a file chooser allowing you to browse and select a text file to import values. File format should be CMYK space delimited.

When you submit your linearisation you will be prompted to enter a name for the curve. If the Pagesetup already has a curve applied then you are presented with a choice. You can either create a new curve with a new name or Overwrite the existing curve.

Effects - If you have several Pagesetups using the same curve then overwriting the existing curve will update all Pagesetups. Creating New will only apply to the Pagesetup you are linearising. If you wanted all your Pagesetups to use the new curve you would need to select each Pagesetup in turn and update them with the new curve.

Lineariser window

The Lineariser window displays all of the patches in the patch window area. If there are no values entered in the patches then they are shown as blank solid patches. If they have values then the patches are displayed in shades of the colour with the density readings in the middle. To change or enter a new value into a patch simply select the square to change to edit mode. Enter the value and press either Enter or Tab to move to the next patch still in edit mode. Select the patch again to come out of edit mode. At the top of the window the Curve Name (if one exists) is displayed along with Pagesetup you are currently linearising. The options for the Linearisation window are as follows.

Advanced Options

- Yule Nielsen number - Enter the Yule Nielsen value if you know what it is for the media you are using.

default = 2

Effects - The Yule Nielsen (YN) number or N-factor is used to compensate for dot spread on different media types. This is basically a “fudge factor” added to the standard Murray-Davis formula used to calculate dot area from a density reading. If you use an N Factor of 1 then no compensation is made and just the Murray Davis equation is used. We have found that a N factor of 2 seems to work well with most media types. As you make adjustments to the values you will see the curve preview on the graph change showing the effect of the value you entered.

- Maximum Densities Override - Enter a value to limit the top end density for each of the process colours.

default = 0 i.e. No override

As you make adjustments to the override values you will see the curve preview on the graph change showing the effect of the value you entered.

- Curves - These are a series of check boxes for each output colour. You can use these to turn off the respective colour in the graph preview.



This is only for the preview and has no effect on the output.

- Clear Patches - This resets all the patches removing all values. This is available as a right mouse click in the patch area of the window.
- Submit Linearisation - This saves the values and attaches it to the Pagesetup you are linearising. If there is already a curve saved to the Pagesetup you are prompted to create a new one or overwrite the existing one. See Submit Linearisation in the Wizard section on page 100 for the effects of New or Overwrite. This option is available from the Linearisation menu.

Cluster Manager

Overview

Clustering is the ability to share the workload of processing jobs across multiple devices. Slaves can be installed on other machines on the network and jobs be sent to them from the master for processing. The cluster manager allows you to add and manage Slave devices. You can enable them to be used for Imaging, Rendering or both. As a Slave devices starts up its speed is calculated. When a job is submitted for processing the master machine has priority as no network traffic is required. If the master is busy processing another job then the job can be sent to the fastest available slave. The Slave processes it and once complete, sends the job back to the master. It is then ready to accept another job. Slaves can be installed on any machine on the network. The options are as follows.

Master

This displays information about the master machine such as platform, version and speed. You can also decide if the Master machine should handle Imaging and Rendering jobs by clicking the appropriate check box. You can also select “Schedule last” which allows Slave nodes to have priority over the master when jobs are processing. This has the advantage when polling large RIPs as it allows the master to concentrate on gathering the list of jobs and displaying them.

Slave Nodes

The slave node list shows the slaves that are available and running on the network.* Information about each slave is displayed in the window. You can enable a slave in the cluster by selecting the check box next to the IP address. You can choose if a slave is to handle Imaging or Rendering jobs or both. Once selected the Master handles the clustering in the most efficient manner. Slave monitoring can be viewed by selecting the Cluster Status Monitor module.



* If there is a node in the list that is greyed out and will not let you select the IP address entry, the slave is off line.

- Add Slave - Allows you to add a slave that cannot be seen. Sometimes slaves on subnets cannot be detected. Selecting this allows you to enter the hostname or IP address of the slave and add it to the list. The slave must be running.

- Refresh - This searches the network for slaves.
- Remove offline slaves - This removes a slave from the list that has gone off line.
- Pick processing pool - Select a Pagesetup Pool for a particular slave. Note: This is available as a contextual menu item (right click) when over a slave only. See HowTo on page 102 for more info.

Column Headings

The Slave Node list contains details about the slave devices available. These are displayed under columns headings. You can customise the view and turn the headings on or off by right clicking in the header area and selecting the columns you wish to view or hide. You can move the position of the column by selecting the name and dragging it along the header bar to your desired position. The column headers available are

- IP Address - The IP Address of the machine that the slave is running on.
- Name - The Name of the machine.
- Speed - The speed as calculated by the slave when it starts.
- Platform - The operating system that the slave is running on.
- CPUs - The number of CPU's the slave platform has.
- Version - The version of software that slave is running.
- Product - The Serendipity Product Name.



HowTo Direct jobs to specific slaves

1. Make sure the slave is running.
2. Create a Pagesetup and configure it as required.
3. Create a Pagesetup Pool and select your Pagesetup. See “Pagesetup Pools” on page 66 for more information.

4. Open the Cluster Manager and right click over the slave. Select “Pick processing pool” from the contextual menu. A Pagesetup Pool chooser will appear displaying the available pools. Select the pool that you created above.
5. You will see the pool under the Processing pool column in the Slave node list. (you may need to expand the window or use the scroll bar.)
6. Submit a job to the Pagesetup or Pagesetup Pool and it should be directed to the slave allocated for processing.
7. Add more Pagesetups or Pagesetup Pools as desired.

Archiver

Overview

The Archiver allows you to make backups or archives of your configurations. Individual items or complete systems can be archived for safe keeping. Archived items can then be loaded into the Archiver for adding into the database. This can be used for copying a system or recovery from failure or corrupt configurations. You can also configure your system to automatically backup your settings on a regular basis.

The window is split, showing a list on the left of the items in the archive. These may have been added from the database or a loaded archive. The right side shows a preview of a selected item on the archive list. There are a few options for the Archiver Application which are available from the top menu (File and Edit) or the context menu (right click). These are as follows.

File Menu

- Open Archive - Open a previously saved archive. This presents you with a chooser allowing you to browse and select an archive to load.



You can also load an archive by dragging it into the archiver.

- Save Archive - Save the archive to a file. Choose a name and suitable location.
- Close Archive - Removes all items from the archive list.
- Perform Full Backup - Adds all your items to a new Archiver window. Once done you are prompted to choose a name and location to save the file. Once saved the Archiver window is dismissed automatically.
- Automatic Backup Preferences - Allows you to configure the frequency, time and location that a system backed up is performed. The options are
 - What Day - Choose a day of the week, every day, every number of days or never.



Note: If you choose every 2 Tuesdays then a backup will be performed every 2nd Tuesday. Alternatively enter the number of

days between backups. e.g. 90 days will run 4 times a year.

- What Time - Choose the time the backup should be performed.
- Location - Choose the location the archive should be saved to.



A check is performed when the client is first started and then every hour afterwards to see if a backup should be performed. The Client must be running for a backup to be done. The table below gives you a guide as to when a backup would be performed in different scenarios.

Table 1:

Auto Backup Time	Client Started	Client Quit	Time Backup Performed
Monday 2am	Monday 9am	No	When client is started i.e. 9am
Tuesday 12.10pm	Tuesday 9.30am	No	Tuesday 12.30pm
Every-day 12am midnight	Tuesday 8.20am	No	When client is started - then 12.20am each day
Wednesday 11pm	Thursday 8.30am	No	The following Wednesday at 11.30pm
Sunday 10pm	Monday 8am	Friday 5pm	Never

Edit Menu (and context menu)

- Add to archive (all) - Select between everything or all of a particular data type e.g. All Pagesetups.

- Add to archive (selection) - This allows you to select individual items from the database to add to the archive. Selecting the type e.g. Gradation Curves, displays a chooser with all the Gradation Curves allowing you to choose one or more to add to the archive.
- Exclude ICC Profiles - This is a toggle which will allow you to create an archive but not include any ICC profiles. Produces a much smaller archive useful for emailing.



Note: This only works when manual selection of archives are performed. When either “Perform full backup” or an automatic backup is done then ICC profiles are always included.



TIP

You can also add items to the archive directly from the Workbench by dragging and dropping them on to Archive list.

- Add to database - Choose to add items from the Archive to the database. You can either add the whole archive or selected items.
- Remove from Archive - Remove the selected items from the archive.
- Expand - Expands selected items if the item contains references. e.g a Pagesetup will contain at least an Output and ICC profiles. Expanding the Pagesetup will display the other items connected with it.
- Collapse - Collapses the selected items if they are expanded.

FlipBook

Overview

The FlipBook is an application that allows you to view a publication as a virtual book. A publication is defined as a collection of pages with the same publication name. This is usually a book or magazine that has been de-imposed but a publication can consist of any number of pages.

You can load the publication and flip through pages as you would a real magazine or book. This allows you to check that your de-imposition has worked correctly. You can check pages are in the correct order, orientation and there are no duplicates. Larger views of the pages can be called up and the whole publication can be exported to PDF.

Starting the FlipBook

There are two ways to start the FlipBook

1. From the Application menu of the Serendipity Client. Choose FlipBook. Once open you can drag a publication into the FlipBook to load it.
2. From the QueueManager by selecting a job and choosing View FlipBook (or using the shortcut key).



From the QueueManager the View FlipBook is only available if the job has a publication name. See [HowTo "Add a publication name to a job."](#) on page 108 for information on creating a publication.

Once you start the FlipBook you will see the window below. This shows a magazine as a complete publication. The pages that make up the publication are shown in the lower half of the window and thumbnails of the pages currently in view.

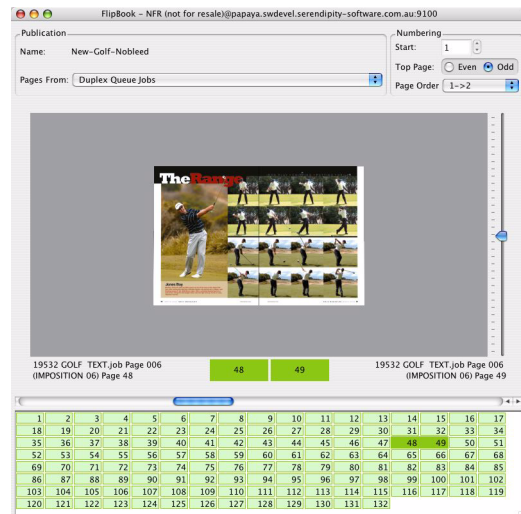

Along the top the loaded publication name is displayed. Below this you have option to choose pages that make up the FlipBook.

- Duplex Queue Jobs - This loads jobs from the same publication name that have a state of “waiting to duplex” or “Duplexed”.
- All Jobs - This loads all jobs with the same publication name.



TIP

If you have a magazine that you have de-imposed ready to duplex then you want to have the pages from the duplex queue only. Otherwise you also get the imposed signatures as these have the same publication name as the single pages and results in having multiple pages the same in the publication.

Numbering is displayed on the top right of the window and gives you a couple of options.

- Start - Enter the page number that is the starting page.
- Top Page - Choose whether the top page is odd or even.
- Page Order - Choose between reading left to right or right to left



TIP

If the first page loaded is page 1 then you cannot alter the start page number. If the first page loaded is greater than 1 then you can enter a lower value as the start page number. This can be used if you are viewing a part publication where all the pages have not been processed yet.

Pages

The bottom section of the window displays the pages that make up the publication. The pages that are displayed are based on the page numbers that are currently loaded in the FlipBook. i.e. the ones finished rendering. The page numbers change colours depending on their state.

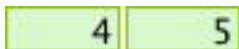

Light Green indicates that the pages are loaded into the FlipBook and can be viewed. These show as dark green when they are selected.

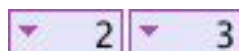

Purple indicates that there are duplicate pages. i.e. they have the same publication name and pages numbers. This may be because All Jobs is selected at the top of the window. (See All jobs



on page 106). Dark purple indicates the pages are selected. Clicking on these pages allows you to select and view the alternative page.

6	19532 GOLF TEXT.job (IMPOSITION) Page 7
22	19532 GOLF TEXT.job Page 007 (IMPOSITION 07)
38	



Light Red indicates that the page is not in the FlipBook. i.e. it is missing. This occurs

because there are other pages greater than the numbers displayed that are there. This could be because that imposition signature has not yet rendered. As they render you can simply reload the publication to update the pages.

Options

When you first start the FlipBook (if started from the QueueManager) the pages of the publication are loaded and displayed in 2D (two dimensional) view. There are various ways to navigate through the publication.

- Clicking on the page of the image - If you click on the right page then you move forward through the publication. If you click on the left page you move backwards through the publication.
- Clicking on the pages of the publication - These are displayed in the lower half of the window. The image jumps to the page pairs that you select.

- Space Bar - The space bar moves forward to the next pair of pages. Hold the shift key and press the space bar to move backwards through the publication.
- PageDown and PageUp - Use these buttons on the keyboard to navigate forward and backwards respectively through the publication.
- Arrow keys - Using down or right arrow keys to move forwards through the publication and left or up to move backwards.
- Scroll bar - Moving the scroll bar below the image moves forwards and backwards through the publication.

Menu Items

There are various options available from the context menu (right mouse click) and the window menus. These are as follows.

- Job Info - Gets information about the currently select page. The job info contains all details of how the job was processed and displays a thumbnail preview of the job and the configuration etc. You can print the Job Info by right clicking on the Job Info window and selecting Print. This will choose a system printer.
- Swap page with - This allows you to swap the currently selected page with another page from the same publication currently loaded in the FlipBook.
- View Imaged - Views the imaged file in the SoftProof application of currently selected jobs.
- View Rendered - Views the rendered file in the SoftProof application of currently selected jobs.



TIP

You can also view the Imaged or Rendered preview by holding the shift key down and clicking on the page that you wish to view. First time you do this you are asked to choose which preview you wish to view (providing the job contains both images). If you leave the SoftProof open you will not be prompted to choose which image type (imaged or rendered) you wish to load next time. The last type chosen will be used as default and will load into the same SoftProof window.

- View 3D - View the publication in three dimension. This shows the page turning as you navigate through. The speed can be adjusted in the preferences.



The performance of the page turning may vary depending on the size of the thumbnail being viewed and performance of the graphics card.

- Once in 3D you can use the slider on the right turn the publication up and down.
- Select the 3D again to go back to 2D.
- To change the size of the thumbnails make the image window (3D area) larger or smaller as required.
- Export - Exports the FlipBook as a PDF. You can select the resolution, compression type and quality. You can also choose between exporting the whole book or a range of pages. You are then prompted for a destination to save the file to.
- Export as spreads - This also exports the FlipBook as a PDF but as spreads. You have the same options as above.
- Export as movie - Exports the FlipBook as a Quicktime Movie. After selecting this you are presented with three options
 - Codec Type - Choose the preferred compression type from the menu.
 - Quality - Choose the preferred quality.
 - Keyframe spacing - Choose how often a keyframe is saved.



TIP

The settings you choose affect the size of the movie, the quality and compatibility. There are many Codec types available and not all work on all systems. Commonly used ones are Apple MPEG 4 and the Sorenson types. Increasing the Quality setting also increases the file size. This is also true for keyframes. The more keyframes you choose i.e. the lower the spacing, the better the quality but the larger the file size. Basically using trial and error you will find the best settings to give you the result you want.

- Borders - This turns borders on/off around the pages. This is useful to see the individual pages when spreads as close fitting. The red boarder shows the click area.
- Smaller Thumbnails - Reduces the size of the thumbnails. You can also use the minus (-) key.
- Larger Thumbnails - Increases the size of the thumbnail. You can also use the plus (+) key.



Boarders and thumbnail size change options are only used in 2D mode.

- Render Queue Thumbnails - This views the Rendered thumbnails instead of the Imaged thumbnails.
- Reload Publication - This reloads the current publication with files from the queue. This is used if additional files have been processed as part of the publication or changes have been made and the publication needs to be updated.



HowTo

Add a publication name to a job.

1. If you submit files for de-imposition you will be prompted to enter a publication name as the last stage of the submit process.
2. When you submit a file for processing from the RIPMonitor or from the Application/Submit menu option you can enter a publication name. By default the publication option is hidden. Clicking on the "Publication" tick box displays two additional options at the bottom of the submit window.

Publication

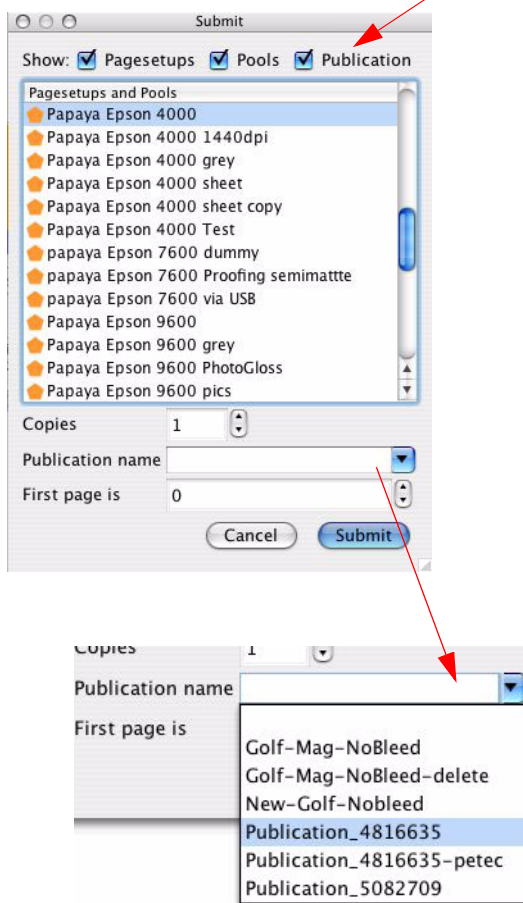

Previous Publications entered

- By modifying the job from the QueueManager and adding a publication. This is done by selecting one or more jobs, choosing modify from the menu and entering a publication name.

Once a job has a publication name it can be viewed in the FlipBook.

MonitorCalibrator

Overview

The MonitorCalibrator is an application that allows you to create an ICC profile of your monitor using a supported spectrophotometer. The profile can then be used to display colour swatches and SoftProof previews accurately. Creation of the profile is very simple requiring one of the supported devices and taking only a few minutes. The device is placed on the screen and a series of measurements taken. From here the profile is created. Below describes the application options and how to use it.

Starting the MonitorCalibrator

Launch the MonitorCalibrator by selecting it from the Application menu. If you have not previously set the match profile and monitor profile in the System Settings then you will be prompted to select both profiles. If you have a match profile to use then select it, otherwise just select a default one for now. Same goes for the monitor profile, a default one will do. These can be changed at any time. Once started you can create a profile for your monitor as described below.

Options

- Profile Monitor - Profiles the monitor using an on-line device. This is greyed out until a supported device is connected and activated.
- Save Display Profile - Saves the measured profile just created. This should be saved in the default ICC monitors directory.
- Monitor Calibrator - Choose one of the supported devices.
- Display Selection - Choose the type of display you are calibrating between CRT and LCD.
- Activate - Activates the selected on-line device. It must be plugged in and powered on to work.



Calibrate your monitor
HowTo

1. Launch the MonitorCalibrator from the Application menu. You will be presented with the window below

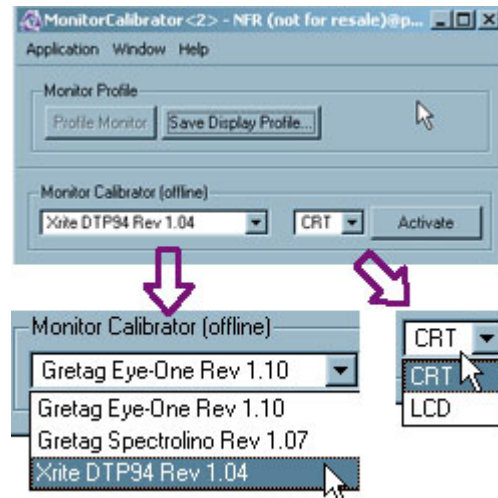

2. Choose the device that you have connected to the client machine.
3. Choose the type of display you have and select the “Activate” button.
4. Depending on the device you will be prompted to get it ready to read, In the case if the Xrite DTP94 you are presented the following window.



5. You need to place the device on an opaque surface such as the desk to calibrate it's offsets. You are then prompted with the next message.

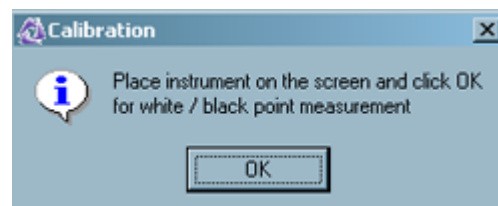

6. Place the device on the screen and press OK. The display will now show black followed by white. Once done you are ready to calibrate.
7. With the device still on the screen select the “Profile Monitor” button. A series of colour patches will display. When finished you need to save the profile.
8. Choose “Save Profile” and choose a suitable location. It is a good idea to place it in monitors

under the ICC directory which is part of the install.



9. Turn the device off and close the application.

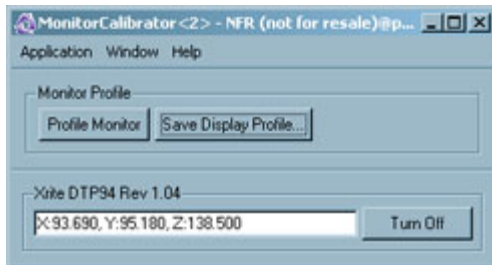

10. You then need to select the profile in the Client System Settings. Choose System Settings from the Application menu.
11. Select Client Settings (middle tab) and select the choose monitor profile button under the Colour Management section.
12. Select OK. See “System Settings” on page 114 for more info.

Each time you update the monitor profile if you save it in the same location with the same name then your client will always use the updated profile. If you choose either a different location or name then you will have to select it in the System Settings each time.

Application Menu Items

Overview

The section covers various utilities and extra functionality that can be accessed through the Application menu. The options are shown below.

Submit Files

Select files to send to a Pagesetup for processing. Choose between Tiff, JPEG, Postscript and PDF. You can select one or more files to submit for processing. Once you select Open you are presented with a chooser showing the Pagesetups and Pagesetup Pools. Select one or more Pagesetups or Pools to submit your files to and click Submit. This will then copy them into the system for processing. You can use the flow control to hold the job after imaging. This places the job in a held state in the rendering queue.

Submit Files For Deimposition

This allows you to submit files for deimposition. After selecting one or more files you are presented with a chooser to select a Pagesetup and then a signature to use for the de-imposing. See deimposing for more info.

Test Prints

Allows you to submit one of the internal test prints for processing. You can select one or more Pagesetups and send multiple copies if desired.

Connect To Server

This allows you to connect to a server that is running on the network. You can search for active servers by clicking the Search button. Choose the server you wish and select Connect. Alternatively you can enter the name or IP address of the server in the Server Address field. The “Server Details” field displays information about the server selected by the Active Servers pull down selector.

If you have multiple servers (Masters) running on the network then the list of the servers is cached on the first “connect to” selection. After that the server selection dialogue appears quickly showing the servers currently cached. If a new server appears after this time the “search” button must be pressed to find the new server and add it to cached list. Likewise, if a server becomes unavailable then the connect will fail

and you must update the list again with the search button.

Authorisation

You can lock the server to prevent changes to the configuration. This allows you to see all options and make changes but you are prevented from saving anything. If you try to save an item when the lock is on a warning message displays instructing you to unlock the server and try again. To lock the server you must first enter a password and verify it. Once done the server becomes locked and the “Lock Changes” menu item shows a tick against it. To make a change to an item you must unlock the server by select the Lock Changes again and entering the password. You are then able to save your changes. Once you have made all of your changes you need to lock the server again to prevent further changes. Your password remains the same until it is either changed or removed. To remove the password select “Change Password”, enter the current password and click OK without entering anything in the new password field. This sets it to none.

ChatterBox

You can Chat to other users connected to the same server as yourself. Selecting the ChatterBox option displays a window showing the clients that are connected to the same server. If the user has entered a Nickname in the System Settings then this name is displayed otherwise the machine name is used. If the users name is greyed out and cannot be selected to start a chat then that user has selected the Away option at the top of the selector window.



To initiate a Chat
HowTo

Select the user and click the Start Chatting. Enter the text and press Send or hit the enter key. Your message is shown next to your name. Your name is either your Nickname as specified in the System Settings or your machine name and is coloured in Green. Messages received from the another user are displayed next the the users name which is coloured Red.

When you have finished your chat simply close the window.

Broadcast Message

This allows you to send a message to all users that are connected with a client to the same server that you are connected to. Selecting the Broadcast option displays a window allowing you to type your message and press send. The message is displayed on the users window for a short time but will automatically dismiss if it is not acknowledged by clicking OK.

Download PPD

This downloads the PPD from the server to your desired location. Selecting this displays a chooser allowing you to navigate where you want to save the PPD on your disk. This saves having to get the PPD off the disk. Use the PPD when installing a local printer.

Quit

This quits the Client. When you quit the session is saved for the next time to start the client. i.e. all the windows and positions that you currently have are saved and remembered.

System Settings

Overview

The system settings contains default values and preferences for the server and client. The system settings are split into 3 tabs, Server settings, Client Settings and Server Info. The Server settings are saved to the server and are therefore common for all clients connected. The Client settings are customise options for the client you are using at that time and may vary between clients and users connected to the same server. The Server Info displays information about the server you are currently connected to such as version number, speed and IP address. The System Settings is available from the Application menu. The details of all the options are shown below.

Server Settings

- Default Units - This allows you to set the units that are used by the server. Choose between mm, inches, cm, points or picas.
- Language encoding for JobNames - Choose between Western or Japanese JIS.
- Maximum memory for PS RIP - Allows you to set the maximum memory that will be used by the Postscript RIP.

Default = 0 - which uses internal setting of 64MB

- Maximum memory for Rotation - Enter the maximum memory that can be used for rotation.

Default = 0 (Server chooses the default depending on system configuration.)

- Low quality Thumbnail - selecting this produces a lower quality thumbnail. This is faster but some detail may be lost in the thumbnail.
- Compression - This controls the compression for the intermediate file format (the imaged file). The choices are Faster or Better.

default - Faster



Selecting Faster improves the performance as it does not take a long to compress the file. However this results in a larger file. If disk space is a priority choose “Better” which produces a smaller file but takes longer. This has not affect on the output quality.

- Maximum Print Preview resolution - Enter the maximum resolution for the rendered preview.

Default = 180 dpi.



TIP

Normally set this low e.g. 72 or 150dpi so it is quicker to generate and the View Rendered option opens faster. For a detail preview the Imaged file can still be viewed unaltered. See also “Maximum Preview Resolution” on page 115

- Polling service refresh - Set the interval between poll service checks i.e. how long between checking to see if any RIPs require polling.

default = 50 seconds

- ICC Engine Accuracy - Select Faster or Better depending on your preference.
- Default Profiles - Select the default profiles that are used when you first create a Pagesetup.
- Apply ICC correction to CMYK Specials - Select this to apply ICC correction to CMYK specials.



By default CMYK specials are not affected by the ICC colour engine. This is generally preferred but in some instances you may want to have your specials corrected by the CMM. This is also a compatibility option for pre version 2.5 Blackmagics.

- Change System Specials - Select a Special Colour Set for plate matching. This is used by the RIPMonitor and Polling service for plate assigning.

Client Settings

- Internationalisation - Select your preferred language from those available. This displays all client and log messages in the chosen language.
- Turn Sound FX Off - Select this if you wish to disable the sound effects. Sound effects are used for things such as drag and drop and error message alerts.

- Instant Messaging Nickname - Enter a nickname that you wish to use for the Chat utility. See “ChatterBox” on page 112.
- Memory Cache maximum size - Sets the maximum cache size for the SoftProof tool.

Default = 0 (Server chooses the default depending on system configuration.)

- Maximum Preview resolution - Sets the maximum preview resolution for the SoftProof Tool for both Imaged and Rendered.

Default = 0 - which is the full job resolution of the output file e.g. 720 dpi and is recommended. See also Maximum Print Preview Resolution on page 114

- Choose Monitor ICC Profile - Select a Monitor profile for the display that you are running the Client on.
- Choose Match ICC Profile - Select a match profile.



The profiles are used so that any colour element viewed on the display is shown as accurately as possible. This is for the Softproof tool and anywhere a colour swatch would be viewed such as the Special Colour Sets. Therefore it is recommended that you calibrate your monitor and you use the same match profile as used in your Pagesetups.

Server Info

This displays information about the Serendipity Blackmagic Server you are connected to and the platform that it is running on.

Special Features

Calibration Guide

Overview

Calibration takes several steps to achieve the optimum output quality available from the printer. Once initial calibration is done then maintenance is quick and easy. The principle for each printer is the same. The steps involved are as follows

- Configuring a Pagesetup
- Creation of a Paper Profile
- Apply ink limits to the Paper Profile
- Linearisation
- Creation of ICC profiles
- Applying ICC Profiles
- Minor adjustments

With this section we will work through calibrating an Epson 4000 step by step. The first section will deal with the quick and simple method which is the automatic Paper Profile creation. At the end of this section there is an experts section which details a manual approach to Paper Profile creation.

Equipment needed

Serendipity Blackmagic
Epson 4000
Suitable media loaded
Densitometer and/or Spectrophotometer.
ICC Profiling software

Before you begin make sure that the printer is running at its optimal level. Check to make sure that the heads are clean and printing correctly.

Configuring a Pagesetup

This is the first and most important step. The Paper Profile is based around the printer driver and the configuration of it. The important elements are resolution, colour space, ink type (Pigment, dye, matt etc.) and the use of light inks or not. If any of these change the Paper Profile must be re-created as the Serendipity Blackmagic server will not process any jobs where there is a mismatch between the values and Paper Profile. Other important values are printing direction and paper type. While these can be changed and the job still process through OK, you may find that the quality is not as good.

We will set the Epson 4000 up as follows

- Ink type - Pigment Black and Light Black
- Resolution - 720 x 720 dpi
- Colour Space - CMYK

- Use Light inks - Yes
- Direction - Uni Directional
- Paper Type - Premium Luster Photo Paper 250

Once you have configured your Pagesetup ready to print then we can create a Paper Profile. See other relevant sections in the manual if you are having difficulty with Pagesetup and output configuration.

Creating a Paper Profile

The aim of the Paper Profile is to better match ink and paper characteristics for a given printer. By printing a chart and measuring it we can better determine how the inks in the machine react to the paper when they are printed. Not all inks and droplet sizes produce good results and therefore we need to determine what works and what does not. The Paper Profile is generated directly from the printer driver based on the settings that you make in the Pagesetup, which is why the Pagesetup needs to be created correctly first.

As we mentioned, the chart that gets printed is generated from the printer driver. It creates a series of squares in the colour space configured, utilising all ink combinations (light and dark) and printer dot sizes (for variable dot devices). For a simple device that does not have light inks and only one dot size this would print one patch per colour space. If the colour space was CMYK then you would get a solid K, C, M and Y. In the case of the 4000 then you get a lot more, 15 in fact which is a combination of light and dark inks and 3 dot or droplet sizes. See the “expert Section” on page 123 for more info and examples.

The squares are measured and then a decision is made as to which combination of dots should be turned off and which should be left on. This section takes the automatic approach and makes the decision for you based on the measurements. If you want to make your own decisions you need to read through the expert section at the end. Here is what you do.

1. Select Paper Profile in the Workbench and create a new one.
2. Choose your new configured Pagesetup and click OK.
3. Enter a name for the Paper Profile.

What you will see is a series of square patches in the colour space you have configured in your Pagesetup. The number will vary as we said depending on the

type of printer and configuration you have selected. For the Epson 4000 configured as above you will see Black, Cyan and Magenta with 16 patches and yellow with 4. The first patch for each colour is to represent the paper value for that colour.

1	2	3	4	5	6	7	8	9	10	11	12	13	14	15	16
D: 0.000	D: 0.000	D: 0.000	D: 0.000	D: 0.000	D: 0.000	D: 0.000	D: 0.000	D: 0.000	D: 0.000	D: 0.000	D: 0.000	D: 0.000	D: 0.000	D: 0.000	D: 0.000
V: 0.000	V: 0.000	V: 0.000	V: 0.000	V: 0.000	V: 0.000	V: 0.000	V: 0.000	V: 0.000	V: 0.000	V: 0.000	V: 0.000	V: 0.000	V: 0.000	V: 0.000	V: 0.000

Print Density Chart

Next you need to print the density chart to the Pagesetup that you are calibrating. Choose “Print Density Chart” from the tool bar options or by right clicking anywhere on the Paper Profile.



This will print a chart that looks the same as the one on the screen. There is no need to turn any other colour management off (if you have any on) in the Pagesetup as everything is automatically disabled. Because the job is generated internally from the print driver there is no preview of the job.

Measure the Patches

Once the job has printed allow it to stabilise for a few minutes. Depending on the printer, inks and media it may come out wet so you will need to let it dry before you measure it. If you have one of the supported on-line Spectrophotometers or Densitometers you need to connect it to the computer where the client is running. Then select the Measure patches option. This will then present you with a list of supported devices. Select the one you have from the list and click OK to continue. The Client will connect to the measurement device and display the measuring window with the first patch highlighted ready to measure. This first patch is the colour or density of the paper you are printing on. Measure each of the patches in turn until complete. The patches will highlight in turn and return to the first patch again once the last patch is read. If you need to re-measure any patch simply click on it and read it again. It then advances to the next patch after a successful read. Click OK when you have read all the patches to close the measure window and store the measurements in the Paper Profile. Then choose File/Save to save the measurements in the database.

manual entry

If you do not have one of the supported devices you need to measure the values for all the patches and enter them into the Paper Profile manually. To do this make sure that the sort patches option is set to patch

number and click on the patch you want to enter a measurement for next to the D or V value. When you have entered the value, pressing the tab or enter key moves to the next patch for the next measurement.

D and V values

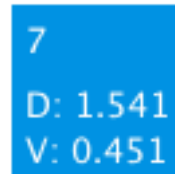

The D value is the density and the V value is the visual. When you use one of the supported on line devices both these values are automatically read and entered for all colours except for the Black. The Density (D) of a colour refers to the colour

content and is the traditional method for measuring density. e.g. a Cyan has a density of 1.5D. The Visual (V) value of the colour refers to how dark the colour is. This is the same as the Black content as Black is an amount of light reflected or absorbed. Both values are measured and used to assess which dot combination works well. See the “Expert Section” on page 123 for more information on assessing the values.

Sifting the results

Once all the measurements have been entered you need sort the values in the appropriate order. For the Black channel select “Black Density” from the pull down menu. For the Cyan and Magenta choose “Visual Density” and for the Yellow choose “Yellow Density”. This will order the colours in the selected mode.

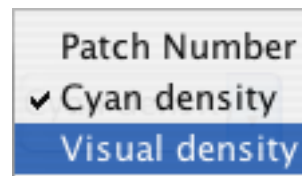

As a general rule if you have a device with light inks then you order those values in Visual Density (except for Black) and others in

Colour Density (or real density). Then select the Sift button for each colour in turn and select an appropriate sifter from the list. For the Epson 4000 we will choose Epson with UltraChrome inks. Once you have sifted each of the colours save the Paper Profile.

Select the Paper Profile

Now that you have an initial Paper Profile you need to select it in the Pagesetup that we are calibrating so that all further prints are done using the Paper Profile we have just created. Go to the Pagesetup, select the Paper Profile and re-save the Pagesetup. Then go back to the Paper Profile ready for the next stage of calibration.

Ink Limits

The next stage in the process is to set ink limits for mixes of ink. We do this by printing a chart out that has increments of one, two, three and four inks mixed. Then for each mix you need to determine at what point the ink bleeds and limit it before it reaches that point, there by restricting the amount of ink on the paper.



Select the “Print Inklimit Chart” from the Paper Profile we are creating and choose the Pagesetup that we are calibrating. If you want to confirm that the Paper Profile is saved to the Pagesetup you can check the preview of the Pagesetup in the submit window. Alternatively choose File>Show Referrers. This will display any Pagesetup using the currently selected Paper Profile. Select OK to print the chart.

When the chart has printed it is a good idea to get the print immediately so that you can see where the inks are dry and where they are wet. For each of the four ink limits determine the point that the mix of inks produce a good neutral colour and are clearly defined. The patches should not bleed or mottle. The Colours of the two inks combined should maintain the colour that the two inks make. i.e. The magenta and yellow produces a red colour so make sure that this stays red. Some inks and papers tend to move towards orange at the upper end and this will give you problems when measuring ICC charts. Same goes for the Blue and Green. Determine the point that the colours produce good balanced results. With modern printers this is generally very easy but some of the older ones produce some strange results so the whole scale needs to be assessed. The single colours should not need to be adjusted. If they do then the Paper Profile patches probably need re-assessing. See the “Expert Section” on page 123. When you have selected the values enter each limit in the inklimit section of the Paper Profile and save it. The Paper Profile is now complete.



With newer printers where the ink saturation is high it is possible to set the ink limits too far up the scale because they still dry with a lot of ink down. But this can cause problems in image areas with real jobs. Do not be afraid to bring the ink limits down. For example with the Epson printers with the K3 inks you can set the ink limits to 100, 175, 230, 250 for the one, two, three and four ink limits respectively.

Linearisation

Once the Paper Profile is made and saved to the Pagesetup we need to linearise the printer. This brings the printer to a neutral known state, making sure for example that a 30% cyan actually prints out at 30%. It does not grey balance the printer. That is handled in the ICC profile. The linearisation process uses a wizard to print and measure a chart to create the linearisation curve. The linearisation curve is automatically applied to the Pagesetup. When the chart is printed all other colour management except for the Paper Profile, is disabled. This way quick linearisation updates can be done without having to remember to disable ICC's, correction curve etc. You basically update the linearisation curve on a regular basis, bringing the printer back to the same point that the ICC profiles were originally applied so maintenance is quick and easy. Print a chart, measure it and apply and continue with your work.

Printing the Linearisation Chart

From the Application menu select the Lineariser. This will display two windows, the lineariser application underneath and the linearisation wizard on top. Select a Pagesetup from the list of available Pagesetups. If a curve already exists in the Pagesetup the graph will display the curve and the name of all the Pagesetups that are currently using the curve. In our example we created a new Pagesetup so there should not be any curve applied. Click next to continue. You are then presented with a list of supported densitometers and spectrophotometers and a manual option. If you have one of the instruments, select it from the list and click Print Chart. The device must be connected to the machine that the client is running on and powered on. The correct linearisation chart is then submitted to the Pagesetup for processing and printing. If the device is not connected an error will occur and no chart is printed. Click next to continue to the measuring window.

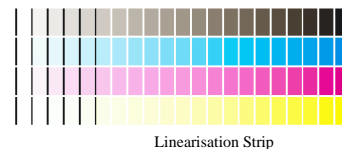

Linearisation Strip

Reading the Linearisation Chart

Depending on the device you have, the patch or strip to be measured will be highlighted. Measure each patch or strip in turn following the instructions at the bottom of the window. If you want to re-measure a patch or strip, select it again and measure it. You can only measure strips with a strip reader or patches with a spot reader.

Submitting the curve

When complete click “submit”. If the Pagesetup did not have a curve applied to it as in the example we are doing, you will be presented with a save window allowing you to enter a name for the curve and OK to save it. When you save the curve it is automatically applied and saved to your Pagesetup. If you do have a curve there then you are presented with a choice. Cancel, Create New or Overwrite. The choice you make depends on your preferred method of working. The consequences of the option you choose are as follows.

- **Cancel** - This does not alter the current curve in any way. The measurements that you have just taken are discarded and the wizard is dismissed. You are left with the Lineariser window showing the patches and curve for the current linearisation applied to the Pagesetup. From here you can enter values manually (see below), adjust the advanced options (see below) and save or close it.
- **Create New** - This creates a new curve based on the reading that you have just taken. You will be asked to enter a new name for the curve and the data will automatically be applied to the Pagesetup. The important thing to note here is that the curve will only apply to the Pagesetup you are calibrating. If you have more than one Pagesetup pointing to the same printer, say a direct output and a nested output you can end up with one Pagesetup being calibrated and the other not. i.e. one will have the old curve and this one the new curve. You must therefore remember to manually attach the new curve to any Pagesetup that currently shares the same curve (providing you want to maintain them the same).
- **Overwrite** - This will overwrite the current curve with the data that you have just read, therefore creating a new curve. This is a good way to keep multiple Pagesetups that point to the same printer with the same media in linearisation. However you also need to be aware that all Pagesetups that reference the curve will have the curve data updated. This may not be your aim. To find out what Pagesetups are using the curve either go back to the first part of the Linearisation wizard and check the Pagesetups that reference it. Alternatively select the curve in any section in the Workbench and select “Show referrers” from the File menu.

Manual Entry

If you do not have one of the supported on-line devices then you can still create a linearisation curve

providing you can take density readings. When you are presented with the choice of devices to choose from, select Manual Entry from the list and print the chart. Then select Finish and you will go straight to the lineariser window. To enter your first value click on the square that corresponds and the number in the box will be highlighted.

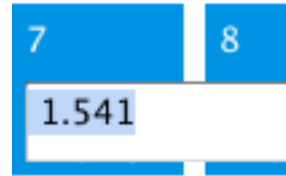

. Enter the density value for that square and press “Return/enter” or “Tab” key to move to the next square. You can click to particular squares if you only have a few

values to enter. Press the Esc key to de-select the number entry box. When you have entered all the values you need to select the “Submit Linearisation” option from the Lineariser menu. This will offer the same options as the automated method. i.e. if the Pagesetup does not have a curve currently then you are prompted to enter a name. If there is a curve there already then you are presented with the choices of “Cancel”, “Create New”, “Overwrite”. See above for the action meanings.

Once all the data has been measured and submitted the Pagesetup and printer should be at a neutral state. This is a state that we can get back to easily by quickly re-linearising. From here you can go on to make your ICC profiles.

ICC Profiles

With your Pagesetup linearised you are ready to create an ICC profile. The first thing to do is to make sure that there are no other colour management settings enabled, except for the Paper Profile we have just created and the Linearisation curve. If you have ICC enabled then turn it off. Make sure that there are no correction curves, dot gains etc. applied. Once done you need to select the ICC chart that you wish to print and send that through the Pagesetup we have linearised. The chart is usually offered as part of the test prints in the ICC software and come as Tiff files. You can print this by creating a drop zone, drop folder or simply using the submit button from the Application menu.



There are instances that you may have a curve applied before the ICC profiles are created. But this is rare and not recommended as a general rule. One reason is that you must always remember that the curve is applied with the ICC profile. If the profile is used without the curve then the values will be wrong. But Linearisation brings the printer to the same point each time.

Assess the chart

When the chart is first printed, examine the patches for any wet inks, smudges, head errors (blocked nozzles) or mottling. If the nozzles are blocked run a head clean and verify they are clear with a test print and then submit the chart again. If there are smudges you need to discard the chart, find the source of the smudging and fix it before you continue. Smudges may cause faulty readings which will not yield very good results.

If the inks are coming out wet you probably need to go back and reassess your Paper Profile ink limiting. If you do make any adjustments in the 2, 3 or 4 ink limits there is no need to re-linearise as the single inks have not been affected. If the patches in the Paper Profile need to be changed then linearisation will be required as the single inks will change as well.

If you see mottling then you can normally remove this by adjusting the ink limits in the 2 or 3 ink limit level and then rendering the chart again. (Re-rendering takes the intermediate file and re-applies all the output colour management as currently set up in the Pagesetup). With some media's (particularly on some older printers) it is difficult to eliminate the mottling, so you need to reduce it as much as possible without compromising too much on the ink limits. i.e. making them too low so there is little density there.

Once you have determined that the chart is good you need to leave it to stabilise before you measure the values. This time will vary depending on the media and ink set, but quite often 30-60 minutes for good quality media with Pigment inks should be sufficient. Once the chart is ready, you need to measure it according to the profiling software's instructions, and create your ICC profile. It is beyond the scope of this document to detail the process of creating an ICC profile. Suffice to say that most ICC profiling software can produce very good profiles and very bad profiles. But they are generated based on the decisions you make and the chart that it reads. The settings will vary depending on the media you are proofing on. You should consult the relevant profiling documentation on the creation of an ICC Profile.

Placing the profile

Once you have your ICC profile created you need to copy it into the ICC Printers directory in the Serendipity Blackmagic software. These are found in the following default locations. (If you installed your software in another location other than the default then go to the installation area)

- Mac OSX
- /Applications/Serendipity/Serendipity Blackmagic/lib/icc/printers
- Windows
- C:\Program Files\Serendipity\Serendipity Blackmagic\lib\icc\printers
- Linux
- \$HOME/Serendipity Blackmagic/lib/icc/printers

Simply copy the ICC profile that you have just created for the printer into one of the folders above. Then go to the Workbench in the Client and choose the Pagesetup that we are calibrating. Find the ICC profile section and choose your newly created ICC profile for the output Profile. This is only half of the ICC profiling solution. Before we can enable the ICC profiling you need a Match profile.

Match Profile

The Match profile or Input profile is also very important. This usually has a greater bearing on the final output quality than the Printer profile. You can have the best printer profile but if the Match profile is rubbish then the system will match rubbish. Therefore a very good match profile is essential for colour calibration. The match profile is a fingerprint of the device that you want to represent on your proof. This should be your press as this is the final product that the customer will get. Therefore your proof should show accurately what the press is capable of and the end result of each job. The process of creating a Press (Match) profile is the same as running a normal print job. The IT8 chart should be passed through your RIP, films or plates created and the job run on the press on a common stock. Leave the chart to stabilise and measure it in the same way as you did for the Printer profile. Again, consult the Profiling Software documentation for details on creating a good profile. The most important thing when creating a Press profile is to make sure that everything is running to optimum performance. The Film and Plate setters are calibrated correctly and the Press is running evenly. This can take some time to adjust but the efforts put in should result in a good quality profile.

Once you have the Match profile you need to copy it into the system as you did for the printer profile. This just needs to be copied into the match folder. The locations are as follows

- Mac OSX
- /Applications/Serendipity/Serendipity Blackmagic/lib/icc/match

- Windows
 - C:\Program Files\Serendipity\Serendipity Blackmagic\lib\icc\match
- Linux
 - \$HOME/Serendipity Blackmagic/lib/icc/match

Once you have placed the input profile into the match folder you need to select that in the Pagesetup that we are calibrating. Once you have selected the Match profile you need to turn on the “Use ICC Always” option and select the rendering intent. See the Pagesetup section “ICC Profiles” on page 59 of the manual for information on each choice. For most pre-press applications the best one to choose is Relative Colorimetric. Save the Pagesetup with the new settings and you are now ready to send a job and check for colour. It is also recommended that you create an archive of your newly calibrated Pagesetup so that you have a working copy on hand. If you have multiple Pagesetups sending to the same device and media then you need to enable the ICC in each and select the ICC profiles, linearisations and Paper Profiles. If you run different media in the printer then you probably need to create new Paper Profile, linearisation and ICC for the printer. But because the press is the same then the match profile can still be used.

Tuning calibration

Some times there are requirements to make small adjustments to the colour. There are a number of tools available for this. Here is an indication on what is available and when you might use them.

Correction LUT

This would be used if you felt that one of the process colours needed adjusting. There is one curve for each and it can be manipulated as desired. Say you find that the proofs are a little too warm in the three quarter tones and you need to drop out some of the magenta. You can create a new curve, select the magenta curve and make your adjustments as required in the troubled area. See “Gradation Curve” on page 44 for information on how to create and alter Gradation Curves.

Dot Gain

When adjusting the calibration with the Dot gain curve you use it when you need to affect the overall view of the job. This is because there one curve for Process colours and one for specials. If for example the proof is coming out too dark then you can apply a Dot Gain curve to lighten the output. See the “Dot

Gain” on page 42 for more information on creating and altering Dot Gain curves.

Tweak Set

An ICC Tweak Set can be applied to alter specific colours. A Tweak Set can only be used when the incoming data is unscreened. If you can identify a particular colour that needs adjusting then that colour can be selected and changed to match the required output. For the Tweak Set to work the Use ICC always must be selected and the ICC profiles and rendering intent used in the Pagesetup must match the ones used when creating the Tweak Set. See the “ICC Tweak Set” on page 46 for more information on creating and adjusting colours with a Tweak Set.

RGB Workflows

If your data coming in is RGB based then you need to create an Input or Match profile for the RGB device you need to match. This profile will be used when ever the data needs to be converted from RGB to CMYK for output, whether or not the “Always Use ICC” is enabled or not. The device can be a scanner, camera or Monitor. The rules for creating a match profile are the same. The RGB profile needs to be placed in following locations.

- Mac OSX
 - /Applications/Serendipity/Serendipity Blackmagic/lib/icc/monitors
- Windows
 - C:\Program Files\Serendipity\Serendipity Blackmagic\lib\icc\monitors
- Linux
 - \$HOME/Serendipity Blackmagic/lib/icc/monitors

Expert section - Manual dot selection of Paper Profile

This section is aimed at the expert that wants to make their own decisions on which dots to use for the Paper Profile and which ones not to. It will take you through the process of assessing the patches and choosing the correct patches, followed by a real scenario. You still need to go through the initial process of creating a Pagesetup, creating a new Paper Profile and printing the density chart out. Please refer the above section for this as it does not change.

As we have discussed the Paper Profile is designed to match ink and paper characteristics for a given printer with a given configuration. If certain parameters change then the Paper Profile will more than likely need to be recreated. This means calibrating again from the beginning as the Paper Profile is the basis of all calibrations.

The Printers

Printers vary greatly as does the ink and media. With newer printers we have light inks and variable dot. With older printers you may just get the basic CMYK. Therefore the patches that you print and read will vary depending on the device. With the older printers the Paper Profile is very basic. A CMYK non variable dot device such as a HP1050 has just one patch (plus the paper density) and as this is either on or off any value can be used

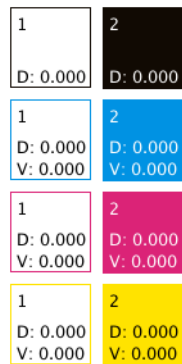

Paper Profile for HP 1050

As you begin to add light inks to printers then the dot selection becomes more important.

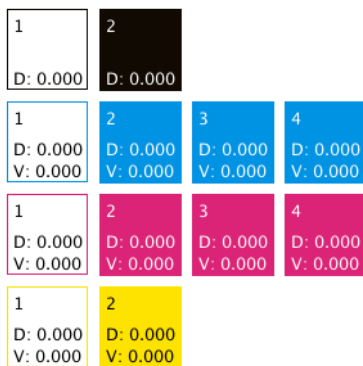

Paper Profile for Epson 9000

Or you can have variable dot.

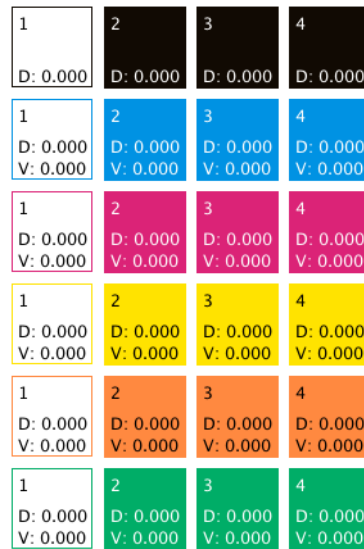

Paper Profile for Roland FJ600 - CMYKOG - No Light Inks

Then with variable dot and light inks the combinations are greater and the selection more complicated.

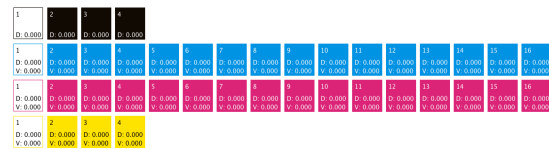

Paper Profile for Epson 10000

The tables below shows the full combination of dots with and without light inks with variable dots.

Patch no	Inks					
	Light Inks			Heavy Inks		
	Dot Size					
	small	med	large	small	med	large
1	✗	✗	✗	✗	✗	✗
2	✓	✗	✗	✗	✗	✗
3	✗	✓	✗	✗	✗	✗
4	✗	✗	✓	✗	✗	✗
5	✗	✗	✗	✓	✗	✗
6	✓	✗	✗	✓	✗	✗
7	✗	✓	✗	✓	✗	✗
8	✗	✗	✓	✓	✗	✗
9	✗	✗	✗	✗	✓	✗
10	✓	✗	✗	✗	✓	✗
11	✗	✓	✗	✗	✓	✗
12	✗	✗	✓	✗	✓	✗
13	✗	✗	✗	✗	✗	✓
14	✓	✗	✗	✗	✗	✓
15	✗	✓	✗	✗	✗	✓
16	✗	✗	✓	✗	✗	✓

light inks, heavy inks and variable dot

Patch no	Inks		
	Dot Size		
	small	med	large
1	✗	✗	✗
2	✓	✗	✗
3	✗	✓	✗
4	✗	✗	✓

Patch no	Inks	
	large light	large heavy
1	✗	✗
2	✓	✗
3	✗	✓
4	✓	✓

light inks and heavy inks

Measuring the patches

After you have printed the density chart, let it dry and stabilise for a short time. Once done you need to measure the patches. There are two methods you can use to read the data into the Paper Profile. Firstly is to use one of the supported on line devices which measures and saves the relevant data direct into the system and this method is recommended. Secondly is to read the density of the patches with another device and manually enter the data via the keyboard. If you are going to input the data manually you need to measure two values for every colour apart from Black. These are the real density and the visual density of each colour and are indicated by D (real) and V (visual) on the interface. Basically the real density is the value of the colour. e.g. the Cyan value of the cyan patch and this is the traditional value we associate with density. The visual density is how light or dark the value is and represented as the black content of the colour. The reason we take both these values will become more apparent when we assess the actual values, but you will notice that sometimes patches that increase in a real density will not always increase in a visual density. Once you have measured all of the patches you need to save the values so that we can begin choosing the patches.

Choosing the patches

There are a few steps to consider when selecting the patches.

Assessing the print

The first thing to do is assess the print. Look for patches that are bleeding, or mottling. Mottling can occur where inks dry at different rates and are not laid down evenly. Sometimes due to the light ink and dark ink not mixing and one drying quicker preventing the other from drying properly. Look for inks that tend to change colour. i.e. some inks in the cyan and magenta tend to shift away from cyan and magenta changing to look more blue and ruby coloured respectively. Once you have identified certain patches that should not be used you can look to turn them off.

You may find it easier initially to sort the patches by Patch number (when saved the patches are sorted in one of the density orders). Then click in the patch's upper half to turn the dots off that you have visually assessed to be poor. Once done sort the patches by either colour (real) density or visual density. As a general rule you sort patches in visual density where light inks are used. i.e. cyan and magenta, and sort the others as real density.

Evaluating the densities

Once you have eliminated visually poor patches you need to look at the density values that you measured

for those patches that are still on. The patches represent a vignette of the colour and therefore must increase as evenly as possible. Taking each colour in turn you need to assess the densities for the sort mode you are in. i.e. if you have sorted visually then assess the visual values first. Make sure that the values of adjacent patches are not too close in value. If they are you get a hump or band in the colour. Generally they should not be any closer than 0.05. If there are two patches side by side that are closer, then you need to turn one of them off. As they have similar densities, keep the one that uses less ink. This can be determined in a couple of ways. The tables above show the dot combinations which you can use as a guide. You can also get the values from the patches or graph points by hovering the mouse over the dots that you need to choose. This will display a tool tip telling you the amount of ink coverage that patch has.

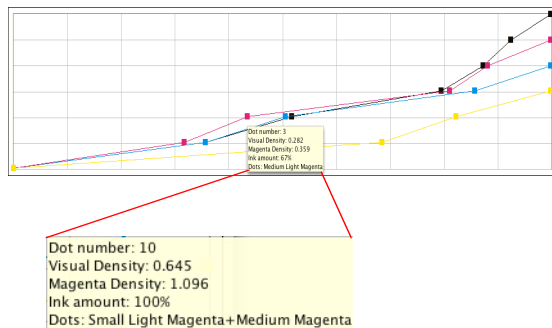

Once you have chosen the values for one sort mode, check the other. i.e. if you have selected the dots for the visual density, change the sort to real density and check for the same criteria. Also, as you change the sort order make sure that none of the patches that are still on switch places with one another. This usually proves to be problematic and you should turn one of them off. Again choose the one that uses more ink to disable. Repeat this for each colour in turn until you are satisfied that your dot selection is good.



TIP

As a general rule we find that the patches 4, 8, 12 and 16 are not very good (where light inks are used), and in particular the Cyan and Magenta. These will often mottle anyway or be very close to an adjacent value. Therefore most times these points will be eliminated by the other processes but if you get problems this is one point to look at.



When turning points off you need to make sure that the last point on has sufficient (real) density required. If not then the proofs will not yield very good results.

The Graph

The graph is used as visual indication of how the values are used. Moving the mouse over a point will display a tool tip giving information about the patch.

It will tell you the dot combination and the ink coverage. The horizontal scale is set in 10% increments. This can be used if you see a problem at a particular point, say 75%. You can see which patch/patches are causing the problems. Each patch is “on” at the point displayed by the graph. They turn on before the patch and switch off after the patch. The point that this happens depends upon the distance of the previous and next patches. They fully merge with the adjacent patches mid way between them.

The graph displays all of the process colours. You can turn the display on and off by checking the tick box below the graph for each colour. This is only a visual display and has no affect on the output.



If the graph does not display for any particular colour (and the checkbox is on) then the points you have selected are poor. If you try to use the Paper Profile in this state the server will error any job processed. The error displayed is “Inconsistent data in Paper Profile, some pixels are lighter or the same density. Please fix and try again”. You will need to re-assess your selection and make some adjustments.

Printing a vignette

After you have made your selection you need to print a chart out and make sure that the dot selection works well on a vignette. Make sure that the sort order is correct and saved. Make sure that the correct Paper Profile is selected in the Pagesetup and that no other colour management is enabled and print a chart with a vignette of each colour. You can download a test chart (shown below) from the Serendipity Software ftp site at <ftp://ftp.serendipity-software.com.au/pub/downloads/GrayBalance-Vignette>

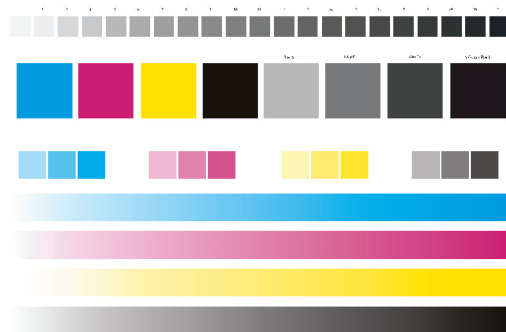

Grey Balance Vignette Chart

Make sure that the vignette is nice and smooth. If you see an area where there is a sharp transition or a hump in the vignette you need to go back to re-assess your selection. Estimate the area where the anomaly is and then use the graph to determine which patch or patches are the problem. Change the ones that you select, save and re-render the vignette chart. Sometimes you may find that changing the sort mode,

say from Visual to Real will fix the problem. This simply moves the points that the dots are turned on and off. Slight problems will most likely be hidden by the linearisation and ICC profiles. Once you are happy that the values are correct you can continue with the calibration process.

Practical Example

In this last section for the Paper Profile we will work through a real example. Taking each decision in turn, explaining the reasons for the choices made and showing the results.

We will profile the Epson 4000 at 1440dpi by 720dpi using Premium luster 250 paper with light inks (pigment) and photo black.

The Pagesetup was configured and saved and the Paper Profile density chart printed. This was measured using an Xrite DTP 34 and the results are shown below.

Patch No.	1	2	3	4	5	6	7	8	9	10	11	12	13	14	15	16	
Black	D: 0.039 V: 0.034	D: 0.057 V: 0.048	D: 1.033 V: 0.278	D: 1.442 V: 0.624	D: 1.274 V: 0.54	D: 1.607 V: 0.617	D: 1.714 V: 0.672	D: 1.458 V: 0.855	D: 1.934 V: 0.758	D: 1.935 V: 0.808	D: 1.904 V: 0.859	D: 1.437 V: 2.035	D: 1.437 V: 2.035	D: 1.687 V: 0.998	D: 1.687 V: 0.998	D: 1.687 V: 0.998	D: 1.687 V: 0.998
Cyan	D: 0.048 V: 0.033	D: 0.745 V: 0.278	D: 1.224 V: 0.367	D: 2.242 V: 0.624	D: 1.658 V: 0.54	D: 2.092 V: 0.617	D: 2.196 V: 0.672	D: 2.261 V: 0.855	D: 2.105 V: 0.758	D: 2.217 V: 0.808	D: 2.273 V: 0.859	D: 2.035 V: 0.998	D: 2.035 V: 0.998	D: 2.238 V: 1.134	D: 2.238 V: 1.134	D: 2.238 V: 1.134	D: 2.238 V: 1.134
Magenta	D: 0.030 V: 0.034	D: 0.404 V: 0.313	D: 0.644 V: 0.439	D: 1.288 V: 0.691	D: 1.106 V: 0.646	D: 1.339 V: 0.712	D: 1.519 V: 0.746	D: 1.785 V: 0.802	D: 1.785 V: 0.802	D: 2.011 V: 0.844	D: 2.011 V: 0.844	D: 2.186 V: 0.899	D: 2.186 V: 0.899	D: 2.315 V: 1.048	D: 2.315 V: 1.048	D: 2.315 V: 1.048	D: 2.315 V: 1.048
Yellow	D: 0.019 V: 0.034	D: 0.048 V: 0.088	D: 0.107 V: 0.107	D: 0.128 V: 0.128													

Paper Profile sorted by patch number for Epson 4000 at 1440 x 720 dpi

The Table below shows the density values of the patches as read. You will see the values that violate the rules and need to be fixed.

Table 1: Starting Densities

Patch No.	Black	Cyan		Magenta		Yellow	
	Rd	Rd	Vd	Rd	Vd	Rd	Vd
1	0.039	0.048	0.033	0.03	0.034	0.019	0.034
2	0.657	0.745	0.278	0.404	0.313	1.041	0.088
3	1.033	1.224	0.367	0.644	0.439	1.243	0.107
4	1.442	2.242	0.624	1.288	0.691	1.307	0.128
5	1.274	1.658	0.54	1.106	0.646		
6	1.607	2.092	0.617	1.339	0.712		
7	1.714	2.196	0.672	1.519	0.746		
8	1.458	2.261	0.855	1.917	0.831		
9	1.934	2.105	0.758	1.785	0.802		
10	1.935	2.217	0.808	1.901	0.826		
11	1.904	2.273	0.859	2.011	0.844		
12	1.437	2.035	0.998	2.186	0.899		
13	1.687	1.997	1.134	2.101	0.967		

Table 1: Starting Densities

Patch No.	Black	Cyan		Magenta		Yellow	
	Rd	Rd	Vd	Rd	Vd	Rd	Vd
14	1.574	1.72	1.198	1.955	0.967		
15	1.53	1.733	1.238	2.029	0.99		
16	1.435	1.814	1.351	2.315	1.048		

Rd = Real Density Vd = Visual Density

From the values you will see that the patches will vary depending on the order that we sort them. For example the highest patch of Cyan when sorted visually is patch 16 at 1.351D. However after sorting the patches by real density patch 16 drops to the 7th position and the top patch is 11 with a real density of 2.273D (patch 16 has a real density of 1.814 D)

Paper Profile sorted by visual density

Paper Profile sorted by real density

The first thing that we do is assess the print for poor patches. From the print done we can see in the black that some patches have printed with a matt finish. These can be eliminated and so 8, 12, 14, 15 and 16 are turned off. In the Cyan and Magenta we see patches 13, 14 15 and 16 print very blue and ruby respectively. As we need Cyan and Magenta colours we can eliminate these patches. Like wise the last yellow patch (4) prints very yellow and has a thin boarder around the patch indicating that it has not dried evenly. So we can eliminate this patch. So from this stage we end up with the following.

Paper Profile after visual assessment

The next stage is to sort the patches and assess them again. We chose to first sort them by visual density. So again starting at the Black we check the values of

the patches and eliminate those according to the rules specified earlier. From the remaining patches we see that patch 13 (1.687D) and patch 7 (1.714D) are close. So we have to choose one of these patches to turn off. By hovering the mouse over the patches we can see that patch 13 will lay down 100% ink coverage being a large heavy ink dot. Patch 7 will also lay down 100% ink (this is a medium light and small heavy). As they have the same effective ink coverage we have to decide via other means which one should be turned off. I chose 13 based on two reasons. Firstly the fact that 13 does not print very well in Cyan and Magenta and it can be assumed that the Black will perform similarly (Black hides some visual artefacts visible in other colours). Secondly that the patch before (6) is made up of a small light and small heavy. By leaving 7 on there is only one ink transition change i.e. that of small light ink changing to medium heavy ink. If we decided to leave the 13 on, then it is a big transition (all ink dot sizes change).



The transition of patches sometimes has an effect in the overall smoothness of the output but not always. It can be one factor used to determine those dots to keep and those to discard.

Patch 11 is close to patch 9 so patch 11 is turned off as this will lay more ink down than patch 9 but both yield similar densities. Patch 10 is turned off for the same reason.

In Cyan we see that patch 4 and patch 8 have adjacent patches that are close (visual density). We chose to eliminate both 4 and 8 even though the adjacent values have the same ink coverage. We choose it based on transition of dot sizes and based on experience.



We know that 4, 8 12 and 16 are generally not very good. If we know this and there are no other factors to separate the patches then it is the only factor that can be used to decide.

Likewise with the magenta we have the same problem with 4 and 8 and these are turned off. But we also have problems with 6 and 7, and 9, 10 and 11. Using the ink coverage rule we can turn off patches 7 and 10. So the Paper Profile now looks like this.

Black densiti	1	2	3	4	5	6	7	8	9	10	11	12	13	14	15	16	17	18	19	20
	D: 0.035	D: 0.057	D: 1.028	D: 1.278	D: 1.435	D: 1.437	D: 1.442	D: 1.438	D: 1.530	D: 1.574	D: 1.603	D: 1.687	D: 1.714	D: 1.904	D: 1.934	D: 1.935				
Visual densiti	1	2	3	4	5	6	7	8	9	10	11	12	13	14	15	16	17	18	19	20
	D: 0.046	D: 0.741	D: 1.124	D: 1.658	D: 2.701	D: 2.242	D: 2.198	D: 2.165	D: 2.210	D: 2.281	D: 2.277	D: 2.193	D: 2.397	D: 2.720	D: 2.733	D: 1.844				
Visual densiti	1	2	3	4	5	6	7	8	9	10	11	12	13	14	15	16	17	18	19	20
	D: 0.080	D: 0.448	D: 0.644	D: 1.100	D: 2.248	D: 1.319	D: 2.510	D: 1.789	D: 2.901	D: 2.927	D: 2.011	D: 2.184	D: 2.953	D: 2.003	D: 2.029	D: 2.315				
Yellow densiti	1	2	3	4	5	6	7	8	9	10	11	12	13	14	15	16	17	18	19	20
	D: 0.019	D: 1.041	D: 1.245	D: 1.307																
	V: 0.034	V: 0.698	V: 0.830	V: 0.128																

Paper Profile sorted by visual density after patch elimination

The next stage is to change the sort mode to real density and again check the density values for patches that are close. As you change the sort also check to see if any patches re-order themselves. And finally make sure that the last patch of each colour has sufficient density to achieve your match criteria.

So for this calibration obviously black does not change as there is only one density value. For Cyan we notice two things. First is that patches 7 and 9 switch depending on the sort order. This also happens with Patches 11 and 12. This can cause us some problems so we need to eliminate one of each of them. Based on the ink coverage rule we choose to keep 9 and 11, and eliminate 7 and 12. We also know that 12 can cause us some problems which is an additional factor in our decision. The next thing we notice with Cyan is that patches 6 and 9 are close in density (and patch 11 is not far off either). Because patch 6 and 9 place the same ink down you have to use other factors to determine the best one to keep. 6 has a smoother dot transition from patch 5, but I chose to turn off patch 6 (based on visual value and assessment) and patch 11 and retain patch 9. We do not need patch 11 as the density is far in excess of that needed for pre-press and patch 11 places more ink than patch 9. So I kept patch 9 as this has a darker appearance (visual density) than patch 6 and it is the last patch. Either would probably yield similar results.

With Magenta the only patch that may cause concern is patch 12. It is close to patch 11 in both real and visual and as we know that 12 can cause some problems (although less so in Magenta) we do not need 12 to achieve a maximum density so we can also eliminate this.

Now that we have assessed the patches visually and the values using both visual density and real density, we are ready to run a vignette test print to see how smooth the resultant patches are. Before we submit the job, change the sort from real to visual for both Cyan and Magenta as this generally produces better results. Then save the Paper Profile. The result is shown below.

Black densiti	1	2	3	4	5	6	7	8	9	10	11	12	13	14	15	16	17	18	19	20
	D: 0.035	D: 0.057	D: 1.028	D: 1.278	D: 1.435	D: 1.437	D: 1.442	D: 1.438	D: 1.530	D: 1.574	D: 1.603	D: 1.687	D: 1.714	D: 1.904	D: 1.934	D: 1.935				
Visual densiti	1	2	3	4	5	6	7	8	9	10	11	12	13	14	15	16	17	18	19	20
	D: 0.048	D: 0.741	D: 1.124	D: 1.658	D: 2.701	D: 2.242	D: 2.198	D: 2.165	D: 2.210	D: 2.281	D: 2.277	D: 2.193	D: 2.397	D: 2.720	D: 2.733	D: 1.844				
Visual densiti	1	2	3	4	5	6	7	8	9	10	11	12	13	14	15	16	17	18	19	20
	D: 0.080	D: 0.448	D: 0.644	D: 1.100	D: 2.248	D: 1.319	D: 2.510	D: 1.789	D: 2.901	D: 2.927	D: 2.011	D: 2.184	D: 2.953	D: 2.003	D: 2.029	D: 2.315				
Yellow densiti	1	2	3	4	5	6	7	8	9	10	11	12	13	14	15	16	17	18	19	20
	D: 0.019	D: 1.041	D: 1.245	D: 1.307																
	V: 0.034	V: 0.698	V: 0.830	V: 0.128																

Paper Profile sorted by visual density before printing first vignette

Then make sure that you select the Paper Profile in the Pagesetup and save before you run the test. Print the vignette and have a look to see how smooth it is. From the print run with this Paper Profile selected I found that Cyan, Magenta and Yellow were all fairly

smooth. But the black had some sharp transitions at the top end. This was around the 80% area. So I had to look at the values of the patches to try to eliminate the transition. One thing to note is that when you turn a dot off, the other dots will move positions to accommodate the change. I tried changing some of the dots at the upper end. For example, turning 9 off and 10 on. This had no noticeable effect. But turning dot 7 off it had a small effect but the transition was still quite severe. Each time you make a change you need to save the Paper Profile and run the job again to see if the change has had the desired effect. Eventually I tried turning off dot 4, which as we know can cause problems. The result was a smooth black vignette. The final Paper Profile used is shown below.

The final Paper Profile used

You will see that there are not many dots actually used. This is a by product of higher resolutions. The essential thing is to get the right combination so that you can create good ICC profiles and get accurate colour matching. After this we now ink limit, linearise and create ICC profiles as detailed earlier in the guide.

Summary

So we now have a nice Paper Profile which we can use to calibrate the system. As you will have realised after reading this last section and after having a go yourself, there is no definite set rule. The Sift button is the best of everything to produce good Paper Profiles. But when creating one manually there are many factors involved in making your decisions. The decisions I made are based on experience gained during a lot of testing. It is not the definitive guide or the only way to choose the patches. You may well get the same end results with different patches. This is a guide to help you understand the process involved and give (as much as possible) the experience gained during development so you can make your own decisions.

The most important thing to understand is that good calibration starts with a good Paper Profile. Because everything else comes from this and if the ink types, dot sizes and paper combinations are not producing very good results at this early stage it will not be helping as we create ICC profiles.

Lineariser - Expert Section

The lineariser is a fairly basic application with very little in the way of expert sections. Its main function is to create a curve for a particular device and apply it to a Pagesetup. The curve is applied on top of the Paper Profile and designed to make the printer linear. Therefore for a given printer and paper Paper Profile you can always return to the linear state from where the ICC profiles are created. It is for this reason that a wizard is used for the first stage to assist guiding you through a standard linearisation. There is an advanced section in the main Lineariser window. This is explained below.

Yule Nielsen Number

As described in the lineariser section of the manual the Yule Nielsen (YN) number is essentially a fudge factor applied to the standard Murray-Davis formula used when calculating dot percentage area from density.

The value is used to compensate for various media types as some react different to others in the way a dot will spread on a particular media and thus affect the dot percentage value. It can sometimes be helpful to change the YN number and some manufacturers will quote a YN number for a given media, but this is rare. The YN formula used for calculating the dot percentage is as follows.

$$\text{Dot \%} = \frac{1 - 10^{-\frac{\text{dot}}{\text{YN}}}}{1 - 10^{-\frac{\text{solid}}{\text{YN}}}} \times 100\%$$

Where dot is the value of the density of the value you are measuring and solid the density of the solid patch. Therefore a Yule Nielsen value of 1 has no effect on the dot percentage area. A value other than 1 will compensate for the dot spread on the media. If the YN is greater than 1 then the dot % decreases and if the YN is less than one the dot% increases. This can be seen from the graph on the lineariser.

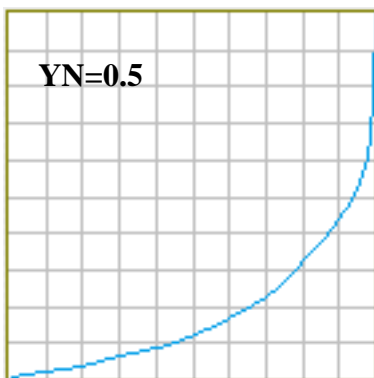
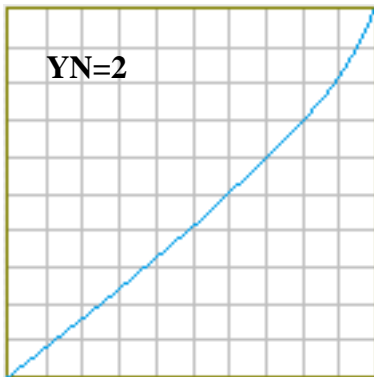
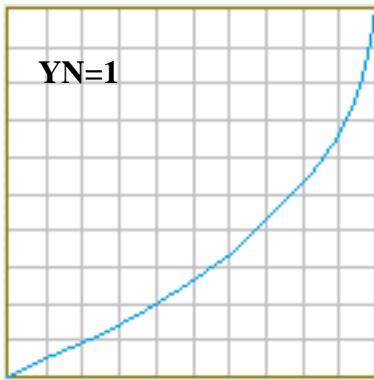

Remember that the curves display the compensation. Therefore if the YN number is less than 1, the dot percentage calculated is increased and so the curve that we apply will go down. The reverse is true for the a YN number greater than 1.

For most of the testing that was done during the development stage the value of 2 (which is the default setting) seemed to work well. However we also noted that on occasions better results were obtainable by setting different values for each process colour.

 Because you create ICC profiles after linearisation, then any value entered will be used for printing the ICC chart and will therefore effect the output. This means that when the

ICC profiles are applied the same YN number must always be used in the lineariser to obtain correct results.

Maximum Densities Override

The only other section in the lineariser is the maximum density override. This allows you to cap the top end density to any value less than the maximum value read. If you enter a value less than the highest value measured then you will see the curve change. The top end will move down and the rest of the curve will adjust to compensate for the new end position. This means that values in the middle will change as well.

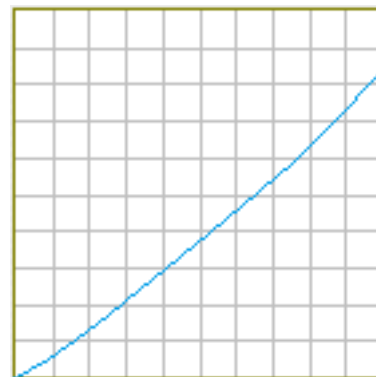

curve with Max density override set to 1.4D - Max measured = 1.7D

Pros and Cons

There are various arguments for and against setting a maximum density override. In general the match ICC profile would set the maximum density values so there should be no need to set them here. However some users have found it an advantage to set the values to the target densities that you require for the final proof output, and doing so have achieved very good results. Reducing the density of the output that is used to print the ICC chart will affect the gamut. However, as the gamut of a press is generally smaller than that of a proofing device this may not have any noticeable effects.



Any value entered in the maximum density override will be used when printing the chart out to create the ICC profile and therefore must always be present when using that profile. This must also be remembered when creating new linearisation curves.

It can sometimes be desirable to drop the top end densities of the output prior to ICC creation. Sometimes there is a need to boost the values after ICC is applied. But really this should only be used as a last resort and is not desirable as a general rule. If the top end densities drop then the ICC profiles are

generally to blame and therefore should be corrected. As mentioned earlier it is the Match profile that has the biggest bearing on the output and that sets the output top end densities.

*** Input Sampling - This is where the sample method is applied and the preserve screen functions etc.

Colour Management diagram

Below is a diagram that shows the flow of data through the various stages of colour management.

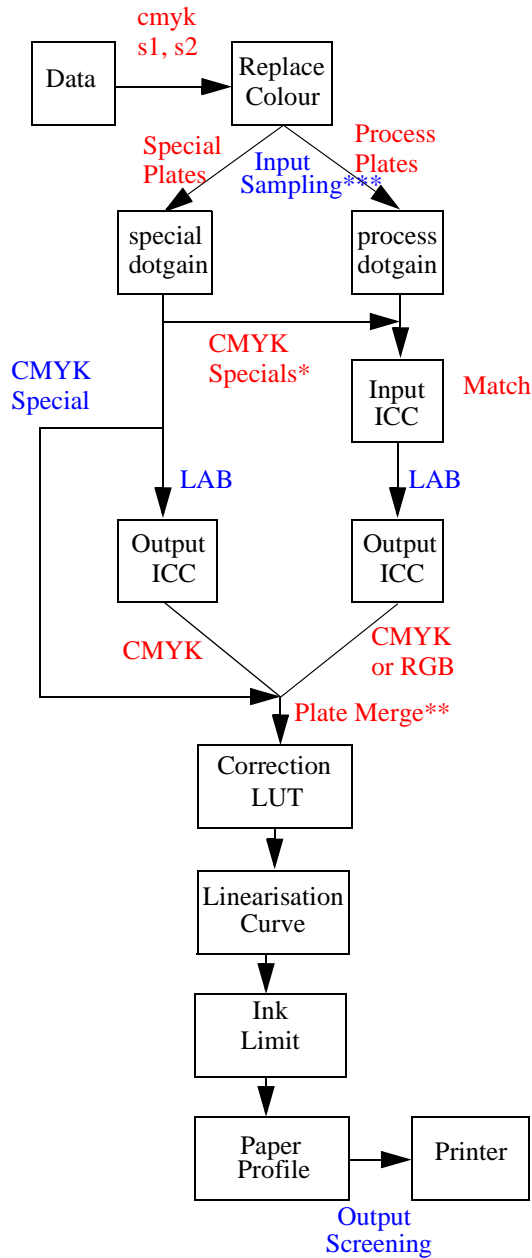

* CMYK Specials - This is the path of CMYK specials if the option “apply colour correction to CMYK specials” is enabled in the system settings.

** Plate Merge - Also at this point the opaque, overprint, knockout and individual colour dot gain curves are applied.

Screen Printing

Overview

The Screen Printing functionality is designed to print film separations on an inkjet printer. A file is submitted for processing which is then separated into the jobs respective plates. Each plate is printed as a black separation with a halftone dot applied at the colours respective screen angle. Because of the requirements of producing a film output the density needs to be higher than with normal proofing. This can be achieved by increasing the resolution so more ink is laid down or by mixing inks, for example black and cyan or magenta. This is done by laying the inks down on top of each other to produce a denser dot. Depending on the media and device densities up to 4.2D can be achieved but this is normally in excess of what is required.

Configuration

The configuration is very similar to a standard setup to print to a device. The output's configuration is the same and an appropriate pagesetup is made to control the page parameters. A very basic Paper Profile and linearisation is made to complete the setup. Below we will work through the configuration step by step and discuss the options available.

The Pagesetup

First thing to do is create the Pagesetup that links to an output to send the data to the device. If you are unfamiliar with creating a pagesetup and output you should read the appropriate sections in the other parts of the manual. Once the Pagesetup is created we can configure the sections required for Screen Printing. These are as follows

- Colour Space - Select CMYK



If you are using the Black patch only then you can choose Gray as the colour space which may result in slightly faster processing.

However in this mode you cannot mix inks to produce a denser output. If you select CYMK and configure a paper profile accordingly then you can choose to use black only or mix it with other colours at a later stage without having to recreate the Paper Profile.

- Resolution - Choose an appropriate resolution.



You can achieve a higher density with a higher resolution but this means it is slower to process and slower to print. Depending on the printer and media you may find that lower resolution produces sufficient density.

- Customise Section - Select appropriate media, choose Uni-Directional or Bi-Directional and turn the "Use Light Inks" off.

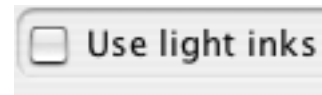

Obviously Bi-Directional is faster but may produce slight banding or may not be as dense as printing in Uni-Direction. Also you can use the light inks if you want and this effects the patches that are available in the Paper Profile. But in the Screen Printing mode you can only have one patch on per colour. In testing better results were achieved by not using the any light inks.

- Screen Printing - Enable Screen Print mode and select black ink.

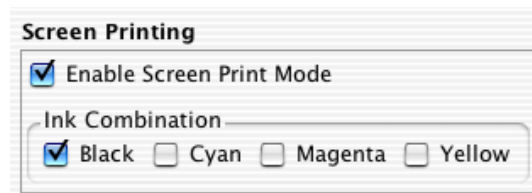

Once you select this option jobs being submitted to this Pagesetup will always be separated and printed using your selected colours. You must select one of more inks to use from the available selection. If you selected Gray as the colour space then you will only see black as the choice. You can mix inks together to produce a more dense output on the film.

- Output Screening - Select Halftone and choose the SuperCell option. Choose your preferred dot shape and enter the preferred screen angles and screen ruling.

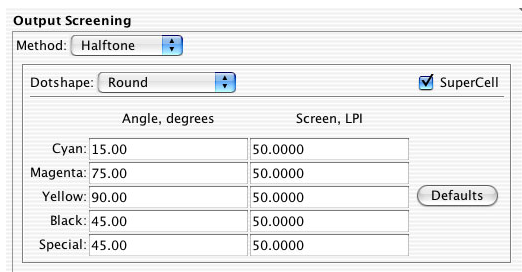

Supercell gives a better shaped dot and the round dot tends to be more commonly used. The default angles of 15, 45, 75 and 90 are shown however these can sometimes produce undesirable effects. These effects are mostly caused by the yellow plate and to counteract this it sometimes desirable to offset all the angles by 7.5 degrees. This would make them the following.

- Cyan - 22.5 degrees
- Magenta - 82.5 degrees
- Yellow - 97.5 degrees
- Black - 52.5 degrees
- Special - 52.5 degrees

The Paper Profile

Once you have the Pagesetup configured you need to save it and create an appropriate Paper Profile. As we have already discussed in the Screen Printing mode you can only have one patch turned on for each colour. Therefore the value for the patch does not matter but which one you choose does.

For a variable dot printer such as the Epson 7600, when the light inks are turned off you will see 4 patches for each colour. The first patch represents the media and the other 3 the dot sizes which are small, medium and large. You must choose one of these dot sizes for each colour.

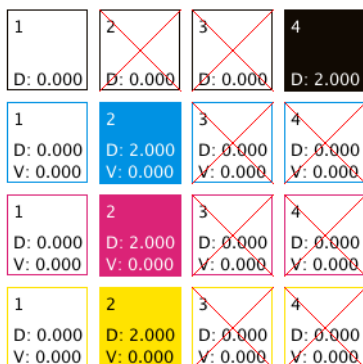

Above shows an example using the patch 4 of the black and patch 2 of each of the other colours. There is no need to measure the value for the patches but a value needs to be entered so we have entered 2 as the

colour density value in our example. You also do not need a visual density value providing you keep the sort set on colour density. See the “Paper Profile” on page 68 in the manual for more information the Paper Profile itself.



You may want to experiment with different sizes of dot. All you need to do is enter a value for another dot and turn it on while turning the other off. In testing we have found that a combination of large black (patch 4) and small magenta (patch 2) produced good results. If you try to use too much, for example large black, large cyan and large magenta you get wet output and the dots tend to ‘fill in’ in the shadow area. If you use large dots of a colour like Cyan then the film comes out looking blue instead of black. So black should always be the dominant colour.

Ink Limiting

There is no need to enter any ink limiting as the plates are separated so there is no mixing of 2, 3 and 4 inks. (This is different to ink combinations in the Screen Printing mode).

Linearisation

Linearisation is very simple and there is no need to use the Lineariser. Creating a simple Gradation Curve and applying it to the pagesetup is the easiest method. In testing we found that the film media reacted fairly linear across the tint values and making an adjustment at 50% was sufficient. And because we are printing black separations then a curve on the black plate is all that is required. Follow the steps below to make a simple linearisation curve.

1. Print a gray scale linearisation chart* through the Screen Printing Pagesetup and measure the 50% value.
2. Create a new Gradation Curve and select the black separation.
3. At the bottom of the editor enter 50 in the input value field, the measured value in the output field and click “Add”.
4. Select “Invert Curve” and save the gradation curve.
5. In your Pagesetup select the Gradation curve just created from the Linearisation chooser and save the pagesetup.

* You can submit one of the gray test charts in the lib/charts directory which is part of the installation. e.g.

lib/charts/dtp34/linearisation_K.bmg

Summary

The above is a guide to configure a setup to print film separations for use in the Screen Printing industry. You need to run some test jobs to choose the most suitable patches, ink combination and resolution for the device and media that you are using. If you choose a different resolution, colour space or the use of light inks then you need to create a new Paper Profile. If you wish to try different sizes of dots then you need to adjust the Paper Profile turning a different size dot on and the current one off.

During the testing period many combinations of ink (colours), dot sizes and resolution were tried. Different output devices and media will produce different results so a different combination of patches and ink mixing may work better. During our testing the higher resolution (1440dpi) produced the most dense output at around 4.18 D but the trade off is in the time it takes to rip and print. By running at a lower resolution (720dpi) the jobs processed quicker but the density drops to just under 3 at around 2.8D. This is often acceptable for a lot of applications but will vary depending on the media and device used and testing will prove the most suitable setup.

The most commonly used settings were CMYK with an ink combination of Black and Magenta. This used the large black (dot 4) and the small magenta (dot 2) and gave a slight reddish tinge to the black which is desirable in the Screen Printing industry.

Using the Xrite DTP20 Pulse

Overview

The Xrite DTP20 Pulse is a spectrophotometer that can be used to read spectral data and density. It is capable of strip and spot measurements and all the relevant client applications support this device. In most of these applications the device is used the same as any other device, connected to the computer and taking spot measurements. However, with the Lineariser application the measurements can be measured either connected (online) or disconnected (offline) from the client in which case they are then downloaded to the application later.



Note: There are two drivers available in the list of supported devices for the DTP20. To follow this section for offline reading then select the Old Firmware driver. To read with the device connected then select the driver version 1.08 or greater. For online measurements your instrument must have Firmware version FB01v1.03 or greater.

This section will detail the Pulse's use with the Lineariser Application using the device offline, how to take measurements and download them. For more information on the Pulse itself please refer to the manufacturers manual.

Lights and Sounds

On the operation button there is a light that changes colour depending on the status. There is also a beep that changes depending on the status. The one important are detailed below.

- Green
 - Solid - Ready to read
 - 2 Pulses then solid - Successful read.
 - slow pulsing - Chart completely read
- Blue - Clear memory
- Yellow - Calibration
- Red - Error
- Red/Orange cycling - Downloading data.

Consult the operators guide for a full list of light indications.

- Beep

- Single short - Read OK
- Single long Dull - Error
- Double - Successful read



HowTo Make a linearisation with the Xrite DTP20

As stated above the measurements are made off line i.e. not connected to the Client. Once all the strips are taken the device is then connected to the computer and the data is downloaded.

1. Print the chart - Although measurements are taken off line the device must be connected to print the chart. Connect the Pulse to the client, start the lineariser, select a pagesetup and device from the list and print the chart. (See "Lineariser" on page 100 in the manual for more info.
2. Clear the pulses memory - Any previously read target data is stored in the device until the memory is cleared. To clear the memory do the following.
 - Press the operation button three times. The light should turn Blue.
 - Press and hold the operation button for about 3 seconds until there is a beep and the light goes out

The light pulses green twice and then turns to a solid green indicating that the instrument is ready to make measurements.

3. Calibrate the device - It is a good idea to calibrate the device before measurement. You need the Pathfinder with the calibration patch for this. To calibrate do the following
 - With the instrument on and light indicating solid green, press the operation button 3 times. The light turns Blue.
 - Press the button 3 more times and the light turns yellow.
 - Place the instrument on the calibration patch and while the light is still yellow, press and hold the operation button to make a calibration.

After a few seconds you will hear a short beep, the light will go out for a short time and then pulse green twice to indicate a successful calibration. This is followed by a solid green light indicating the instrument is ready to take measurements.

4. Read the Chart - The chart has an additional strip called a target ID that must be read first to set the instrument up. This tells the instrument the type chart it is reading. Make sure the instrument has a solid green light on.

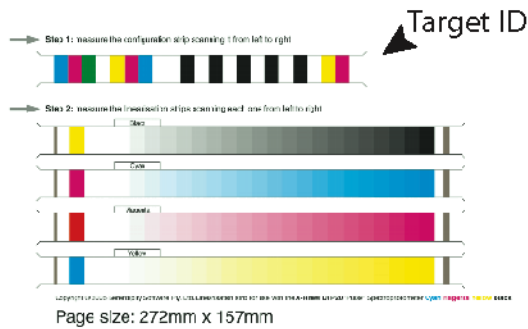

- Position the chart on the backer board and position the path finder guide so the reading window is over the target ID.
- Place the instrument on the Pathfinder at the start of the strip.
- Press the operation button once. You hear a short beep and the green light goes out.
- Slide the instrument to read the target ID.

After it has read the strip you should hear a double beep followed by 2 short pulses of the green light to indicate that it has read successfully. The light then turns solid green.



A dull beep and red flashing light indicates a bad reading. When the light turns solid, re-read the target ID. If the problem persists re-calibrate and try again.

- Move the pathfinder guide to the black strip.
- Press the operation button. After a beep slide the instrument along the strip to read it.

A successful read is indicated by a double beep, followed by two short pulses of green light and then a solid green.

- Repeat reading each strip in turn.

Once you have read all the strips on the chart the instrument will show a slow green pulsing light. This indicates the whole chart has been read successfully. If you get any errors reading any strip, wait until the light displays solid again and re-read that strip.

5. Download the data - Once all read you need to download the readings to the client.

- Connect the device to the USB port on the client.
- Launch the lineariser, select the pagesetup and click next.
- Select the Pulse from the list and click next.

The pulse will start to download the measurement data to the Lineariser application. The light on the device should pulse red/orange as it is downloading. Each strip will report loading data and once they are all done, measurement OK will be displayed. Continue with the lineariser in the normal way. See “Lineariser” on page 100 for more information.



If you get an error while downloading the data then you need to start the download again. Just press the back button to take you back one step and then Next to start the download again.



Errors in reading are usually caused by reading too fast. Use a steady motion from start to finish and make sure you don't move too fast.

Setting up a DoubleProof or SpinJet

Overview

Double sided proofing can be achieved using various double sided printer. This document will guide you through setting up and configuring the pagesetup to successfully print front and back and show you the adjustments needed to back the images up accurately. The printers currently supported are the Fuji DoubleProof and the Techsage SpinJet. The setup described below was done on a DoubleProof 5000 using a roll of media that was 1067mm wide. For the front and back calibration a test file was created for this size media. This test file called doubleproof_centreing.pdf can be downloaded from the Serendipity ftp site at the following location

<ftp://ftp.serendipity-software.com.au/pub/downloads/>

Configuration

It is assumed that you have the printer switched on and loaded with media. And that you already have a valid output configured that will print to the device and it is selected when creating the Pagesetup. The correct driver for the 5000 machines is the Doubleproof / Spinjet 5000.

In order to successfully back up the front and back side prints you need to configure two pagesetups. One for the front side and one for the back side. Both point to the same printer and vary only in margin and rotation depending on your working method e.g. work and turn, work and tumble etc.

The Pagesetups

The first one we create is called “DoubleProof - front”. This is configured as a standard pagesetup selecting the preferred printing resolution. e.g 600 x 600 dpi.



The type of paper loaded automatically for the second sheet is the first paper type in the list as specified by the printer. This is a HP Coated media and as such is limited to one of two printing quality or Normal or Best. Normal is the fastest method which is a Productivity setting.

In the customise section you are presented with the following options.

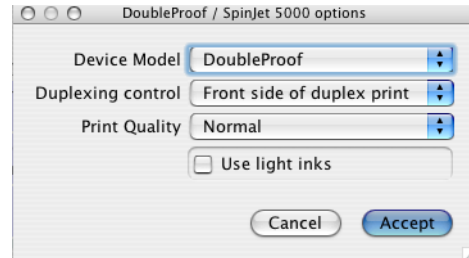

From this you need to select the following options.

Device

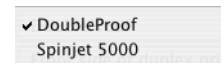

Duplexing control

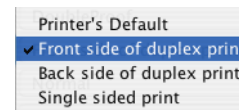

And finally choose your quality type

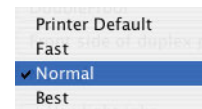

Once selected you need to save the Pagesetup. You can then duplicate this changing the name to be “Doubleproof - back”. For the back setup you need to change the duplexing control to be the “Back side of duplex print”. Also you need to set the rotation (under the sheet settings) to be 180 degree

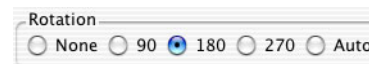

This is to facilitate both heads at the top of the page. This can be changed later to suite your workflow. Save the back Pagesetup.



IMPORTANT - Make sure that you do not have the slugline or logo box enabled on either Pagesetup as these are placed outside the image but form part of the job. This will effect where the image is positioned making it difficult to align.

The Output

The next thing you need to do is setup the duplexing mode. Select the output that you are using to print to

the device. At the bottom in the collating section select collation method as Duplexing.

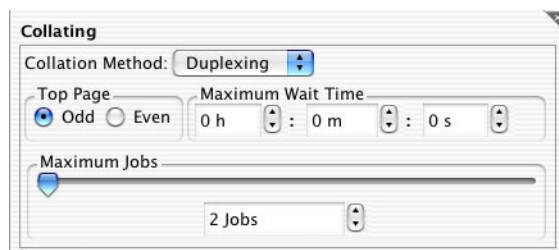

✓ Duplexing
Nesting

Set the Top page as Odd and the Maximum Jobs to 2. This means that every two pages will be duplexed to create a single page (two sided) job.

The Test Page

You can create your test page if you wish. The basic principles are to make it the full width of the media with some part of the image all the way to the end and to make the depth long enough to allow double sided printing to take place. The specification for this should be in the user guide of the device. For our test job for media 1067mm wide the job looks like this.

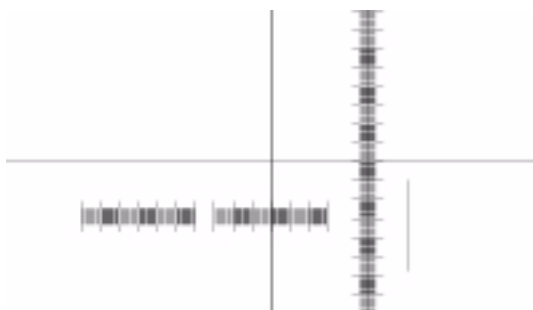

The job is 1067mm x 540mm and has a cross exactly in the middle stretching to the edges of the dimension. This enables you to determine where the printable area is so that you can select the correct margins.

Printing the job

To print the job, follow the instructions below.

1. Select "Submit" from the Application menu.



2. Choose the job and select Open.

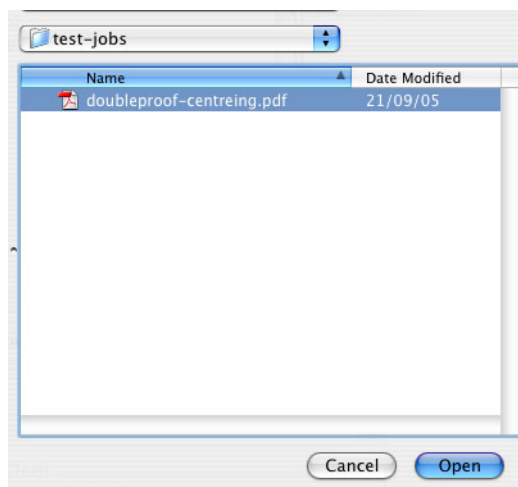

3. Choose the Front side Pagesetup from the list. Enter a publication* name, make the first page to be 1 and select Submit.

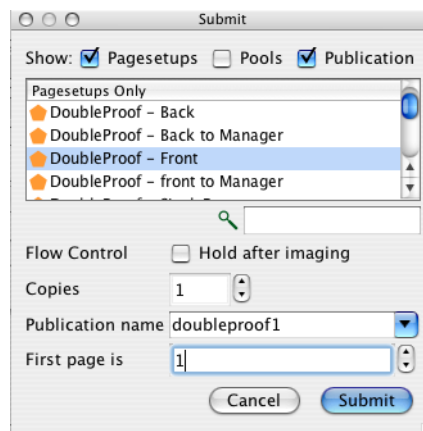

* If the publication pull down is not available then you need to select the Publication tickbox at the top of the window.

This will send the test job to the front Pagesetup. So you now need to repeat the procedure to send the

same test job to the back pagesetup. The only difference is you enter the first page is 2. See below.

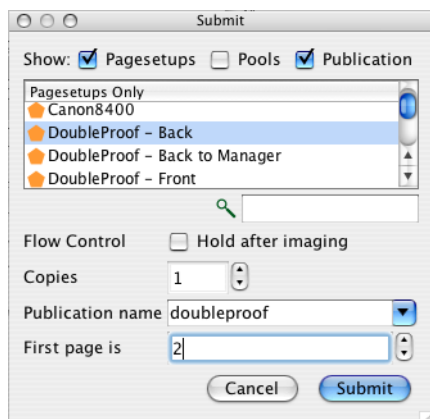

You need to make sure that you select the same publication as this will make sure that it gets duplexed with the front page also going to the same publication. Here we used the name doubleproof but you can use anything as long as front and back (page 1 and 2 respectively) are assigned to the same publication.

This will process the two files. The Back side will rotate 180 degrees. As the first job appears in the output queue it should have a status of “waiting to duplex”. When the back also appears in the queue it will have the same state for a short time and then duplexing will begin. A new job will be created which is a combination of the two single sides. The first side will print, cut and be held by the double sided unit. The roll media will unload and the held sheet will load back in and align ready for printing. The second page of the duplexed job will then print and you can begin your calibration.



Important - Make sure that you mark the lead of the job for the front and back pages as they are printing. You need to know which is the top of the job and which is the front in order to calibrate successfully.

Printer specifics

The way the printer is configured, the first part of the job is the top and the left and right are taken from the media feed direction as it is printing. See diagram

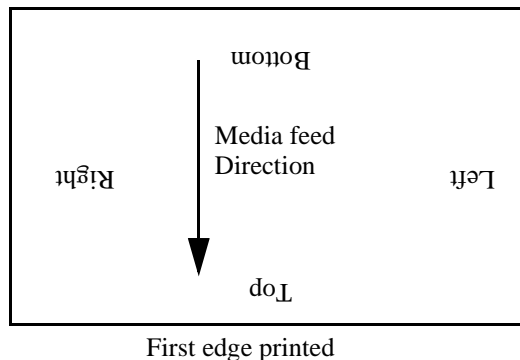

As the printer feeds this way the double proofing unit holds the media by the bottom. When the roll has unloaded the bottom is fed back into the printer and is therefore the first out. Because we rotate the back page by 180 degrees the first part of the job printed is the bottom. This will therefore line up with the bottom of the front page.

Calibration

Lay the sheet on a table and measure the margins. This is the distance between the edge of the media and start of the image. You need to measure front and back and you can enter the details on the test print. Measure the vertical line length front and back also. For the device used for this document the following values were measured.

Table 1: Uncalibrated Values

	Front	Back	Gap
Left	6.0	5.5	
Top	7	18	
Right	3.5	8	
Bottom	6	36	
Vertical			30
Horizontal			2
Measurements in mm			



If you have a light table you can measure both back and front from the front.

The line length for the front was 540mm which it should be as this is the first page printed. The back however was 499mm. This is because there was not

enough front page to allow the back page to print as a sheet. Being a sheet it needs more area to grip the page.

To do this take the values measured as the back top and bottom margins and enter those values as the front margins under sheet options.

Margins	
Left:	0.0 mm
Top:	18.0 mm
Right:	0.0 mm
Bottom:	36.0 mm

Select the DoubleProof - front Pagesetup and enter the values you measured as shown above. Save the Pagesetup and repeat the process of submitting the test print to front and back as before. This time when job has printed the vertical gap should be a lot closer and the line vertical length should be 540mm indicating that there is now sufficient page area to print the job as a sheet on the back.

The final part is to bring into alignment the vertical and horizontal lines. In the test print you can use the printed rules to determine the gap. With this print I can see that my vertical gap is 5.5mm and horizontal gap is 2 mm. (The horizontal gap was actually measured from the first print and you can enter that value in the first step if you wish). The only thing to determine is which way the image needs to be moved.

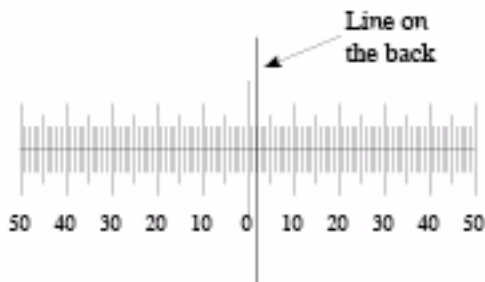

Looking at the horizontal line first I can see that front image (shown by the rule) needs to be pushed to the right for it to line up. Therefore I need to place a 2mm margin on the left margin of the front sheet. If the line

was the other side of the 0 I would then have to enter a back left margin to push the back image away from the edge to the right.

For the Vertical margin I can see the front image is higher than the back. But you cannot move the front image down because this then shifts the bottom margin and so the gap does not get smaller. You therefore need to shift the back. Remember which part of the back is printed first you can determine the direction to move the image and it should always be the lead. For our configuration where the back is rotated the lead image is the bottom of the job. But the rotation happens before the margins are set. Therefore the margin must be entered as a top margin on the back side Pagesetup.

Select the DoubleProof - back Pagesetup and enter a top margin of 6mm. Save the pagesetup and you can print the job again to check and make small adjustments to the margins if necessary.

Limitations

You should be able to achieve a high accuracy when backing up. You can correct for paper stretch by using the accuracy correction but this will alter the size of the image printed and you may need to adjust your margins again. There is no way in the software at present to compensate for skew. The only way to fix this is to reload the paper. Subsequent loads may alter paper position slightly and therefore margin may also need adjusting so it is good practice to run the test job out again to check after each new roll is loaded.

Appendix

Glossary

Client - GUI that monitors jobs and allows configuration of the server.

Clustering - The use of multiple machines on a network for distributed processing.

CMM - Colour Management Module.

CRT - Cathode Ray Tube. Describes the type of monitor.

CTP - Computer to Plate

Data types - Database groups such as Pagesetups or RIPs etc.

DPI - Dots Per Inch (resolution)

EPS - Encapsulated Postscript File

FTP - File Transfer Protocol - Method for copying files between computers across networks.

GUI - Graphical User Interface.

ICC - International Color Consortium

ICC Profile - A colour lookup table that is used for converting colour of a job from one device to another.

LAN - Local Area Network

LCD - Liquid Crystal Display

LPI - Lines Per Inch (screen ruling)

Master - A master server control Slave nodes in a Clustering environment.

Post RIP data - Files after the RIP has processed them. These are usually 1 bit data or contone data in the format to go to a CTP or Imagesetter.

QueueManager - Client module that displays job queues and any jobs in those queues.

Queue Status - Monitors the progress is a job through the system.

RDT - Real Dot Technology

Real Density - Colour content of a patch as measured.

RIPMonitor - Client module which shows valid RIP files ready for processing.

RIP - Raster Image Processor

Server - Software module that handles the processing of jobs.

Slave - A separate processing node on the network. Used for processing jobs by a Master.

TCP/IP - Transmission Control Protocol / Internet Protocol

Visual Density - The darkness of the patch measured. i.e. how much light is absorbed. The more light absorbed the darker the visual density.

WAN - Wide Area Network

Workbench - Serendipity Client Application used to configure the server.

YN - Yule Nielsen Number

Yule Nielsen Number - A “fudge factor” used when calculating % tint (dot area) from density readings.

Copyright Notices

PNG Library Copyright

Copyright (c) 1995, 1996 Guy Eric Schalnat, Group 42, Inc.

Contributing Authors:

Andreas Dilger, Dave Martindale, Guy Eric Schalnat, Paul Schmidt, Tim Wegner

The contributing authors would like to thank all those who helped with testing, bug fixes, and patience. You know who you are. This wouldn't have been possible without all of you.

Thanks to **Frank J. T. Wojcik** for reviewing the documentation

The PNG Reference Library is supplied "AS IS". The Contributing Authors and Group 42, Inc. disclaim all warranties, expressed or implied, including, without limitation, the warranties of merchantability and of fitness for any purpose. The Contributing Authors and Group 42, Inc. assume no liability for damages, direct or consequential, which may result from the use of the PNG Reference Library.

Permission is hereby granted to use, copy, modify, and distribute this source code, or portions hereof, for any purpose, without fee, subject to the following restrictions:

1. The origin of this source code must not be misrepresented.
2. Altered versions must be plainly marked as such and must not be misrepresented as being the original source.
3. This Copyright notice may not be removed or altered from any source or altered source distribution.

Compression Library Copyright

(C) 1995 Jean-loup Gailly and Mark Adler

This software is provided 'as-is', without any express or implied warranty. In no event will the authors be held liable for any damages arising from the use of this software.

Permission is granted to anyone to use this software for any purpose, including commercial applications, and to alter it and redistribute it freely, subject to the following restrictions:

1. The origin of this software must not be misrepresented; you must not claim that you wrote the original software. If you use this software in a product, an acknowledgment in the product documentation would be appreciated but is not required.
2. Altered source versions must be plainly marked as such, and must not be misrepresented as being the original software.
3. This notice may not be removed or altered from any source distribution.

Jean-loup Gailly Mark Adler
gzip@prep.ai.mit.edu madler@alumni.caltech.edu

Independent JPEG Group's Copyright

The authors make NO WARRANTY or representation, either express or implied, with respect to this software, its quality, accuracy, merchantability, or fitness for a particular purpose. This software is provided "AS IS", and you, its user, assume the entire risk as to its quality and accuracy.

This software is copyright (C) 1991, 1992, 1993, 1994, 1995, Thomas G. Lane. All Rights Reserved except as specified below.

Permission is hereby granted to use, copy, modify, and distribute this software (or portions thereof) for any purpose, without fee, subject to these conditions:

1. If any part of the source code for this software is distributed, then this README file must be included, with this copyright and no-warranty notice unaltered; and any additions, deletions, or changes to the original files must be clearly indicated in accompanying documentation.
2. If only executable code is distributed, then the accompanying documentation must state that "this software is based in part on the work of the Independent JPEG Group".
3. Permission for use of this software is granted only if the user accepts full responsibility for any undesirable consequences; the authors accept NO LIABILITY for damages of any kind.

These conditions apply to any software derived from or based on the IJG code, not just to the unmodified library. If you use our work, you ought to acknowledge us.

Permission is NOT granted for the use of any IJG author's name or company name in advertising or publicity relating to this software or products derived from it. This software may be referred to only as "the Independent JPEG Group's software".

We specifically permit and encourage the use of this software as the basis of commercial products, provided that all warranty or liability claims are assumed by the product vendor.

ansi2knr.c is included in this distribution by permission of **L. Peter Deutsch**, sole proprietor of its copyright holder, **Aladdin Enterprises of Menlo Park, CA**. ansi2knr.c is NOT covered by the above copyright and conditions, but instead by the usual distribution terms of the Free Software Foundation; principally, that you must include source code if you redistribute it. (See the file ansi2knr.c for full details.) However, since ansi2knr.c is not needed as part of any program generated from the IJG code, this does not limit you more than the foregoing paragraphs do.

"The Graphics Interchange Format(c) is the Copyright property of CompuServe Incorporated. GIF(sm) is a Service Mark property of CompuServe Incorporated."

Copyright © 1980, 1993

The Regents of the University of California. All rights reserved.

Redistribution and use in source and binary forms, with or without modification, are permitted provided that the following conditions are met:

1. Redistributions of source code must retain the above copyright notice, this list of conditions and the following disclaimer.
2. Redistributions in binary form must reproduce the above copyright notice, this list of conditions and the following disclaimer in the documentation and/or other materials provided with the distribution.
3. All advertising materials mentioning features or use of this software must display the following acknowledgment:
4. This product includes software developed by the University of California, Berkeley and its contributors.
5. Neither the name of the University nor the names of its contributors may be used to endorse or promote products derived from this software without specific prior written permission.

THIS SOFTWARE IS PROVIDED BY THE REGENTS AND CONTRIBUTORS ``AS IS'' AND ANY EXPRESS OR IMPLIED WARRANTIES, INCLUDING, BUT NOT LIMITED TO, THE IMPLIED WARRANTIES OF MERCHANTABILITY AND FITNESS FOR A PARTICULAR PURPOSE ARE DISCLAIMED. IN NO EVENT SHALL THE REGENTS OR CONTRIBUTORS BE LIABLE FOR ANY DIRECT, INDIRECT, INCIDENTAL, SPECIAL, EXEMPLARY, OR CONSEQUENTIAL DAMAGES (INCLUDING, BUT NOT LIMITED TO, PROCUREMENT OF SUBSTITUTE GOODS OR SERVICES; LOSS OF USE, DATA, OR PROFITS; OR BUSINESS INTERRUPTION) HOWEVER CAUSED AND ON ANY

THEORY OF LIABILITY, WHETHER IN CONTRACT, STRICT LIABILITY, OR TORT (INCLUDING NEGLIGENCE OR OTHERWISE) ARISING IN ANY WAY OUT OF THE USE OF THIS SOFTWARE, EVEN IF ADVISED OF THE POSSIBILITY OF SUCH DAMAGE.

Copyright © 1990,1994 Regents of The University of Michigan.

All Rights Reserved.

Permission to use, copy, modify, and distribute this software and its documentation for any purpose and without fee is hereby granted, provided that the above copyright notice appears in all copies and that both that copyright notice and this permission notice appear in supporting documentation, and that the name of The University of Michigan not be used in advertising or publicity pertaining to distribution of the software without specific, written prior permission. This software is supplied as is without expressed or implied warranties of any kind.

This product includes software developed by the University of California, Berkeley and its contributors.

Code in sys/linux is developed by Alan Cox. You may redistribute it and/or modify it under the terms of the GNU General Public License as published by the Free Software Foundation; either version 2 of the License, or (at your option) any later version.

Research Systems Unix Group

The University of Michigan

c/o Wesley Craig

535 W. William Street

Ann Arbor, Michigan

+1-313-764-2278

netatalk@umich.edu

GNU GENERAL PUBLIC LICENSE

Version 2, June 1991

Copyright © 1989, 1991 Free Software Foundation, Inc.

675 Mass Ave,
Cambridge,
MA 02139, USA

Everyone is permitted to copy and distribute verbatim copies of this license document, but changing it is not allowed.

Preamble

The licenses for most software are designed to take away your freedom to share and change it. By contrast, the GNU General Public License is intended to guarantee your freedom to share and change free software—to make sure the software is free for all its users. This General Public License applies to most of the Free Software Foundation's

software and to any other program whose authors commit to using it. (Some other Free Software Foundation software is covered by the GNU Library General Public License instead.) You can apply it to your programs, too. When we speak of free software, we are referring to freedom, not price. Our General Public Licenses are designed to make sure that you have the freedom to distribute copies of free software (and charge for this service if you wish), that you receive source code or can get it if you want it, that you can change the software or use pieces of it in new free programs; and that you know you can do these things.

To protect your rights, we need to make restrictions that forbid anyone to deny you these rights or to ask you to surrender the rights. These restrictions translate to certain responsibilities for you if you distribute copies of the software, or if you modify it.

For example, if you distribute copies of such a program, whether gratis or for a fee, you must give the recipients all the rights that you have. You must make sure that they, too, receive or can get the source code. And you must show them these terms so they know their rights.

We protect your rights with two steps: (1) copyright the software, and (2) offer you this license which gives you legal permission to copy, distribute and/or modify the software.

Also, for each author's protection and ours, we want to make certain that everyone understands that there is no warranty for this free software. If the software is modified by someone else and passed on, we want its recipients to know that what they have is not the original, so that any problems introduced by others will not reflect on the original authors' reputations.

Finally, any free program is threatened constantly by software patents. We wish to avoid the danger that redistributors of a free program will individually obtain patent licenses, in effect making the program proprietary. To prevent this, we have made it clear that any patent must be licensed for everyone's free use or not licensed at all. The precise terms and conditions for copying, distribution and modification follow.

GNU GENERAL PUBLIC LICENSE

TERMS AND CONDITIONS FOR COPYING, DISTRIBUTION AND MODIFICATION

0. This License applies to any program or other work which contains a notice placed by the copyright holder saying it may be distributed under the terms of this General Public License. The "Program", below, refers to any such program or work, and a "work based on the Program" means either the Program or any derivative work under copyright law: that is to say, a work containing the Program or a portion of it, either verbatim or with modifications and/or translated into another language. (Hereinafter, translation is included without limitation in the term "modification".) Each licensee is addressed as "you".

Activities other than copying, distribution and modification are not covered by this License; they are outside its scope. The act of running the Program is not restricted, and the output from the Program is covered only if its contents constitute a work based on the Program (independent of having been made by running the Program). Whether that is true depends on what the Program does.

1. You may copy and distribute verbatim copies of the Program's source code as you receive it, in any medium, provided that you conspicuously and appropriately publish on each copy an appropriate copyright notice and disclaimer of warranty; keep intact all the notices that refer to this License and to the absence of any warranty; and give any other recipients of the Program a copy of this License along with the Program.

You may charge a fee for the physical act of transferring a copy, and you may at your option offer warranty protection in exchange for a fee.

2. You may modify your copy or copies of the Program or any portion of it, thus forming a work based on the Program, and copy and distribute such modifications or work under the terms of Section 1 above, provided that you also meet all of these conditions:
 - a). You must cause the modified files to carry prominent notices stating that you changed the files and the date of any change.

- b). You must cause any work that you distribute or publish, that in whole or in part contains or is derived from the Program or any part thereof, to be licensed as a whole at no charge to all third parties under the terms of this License.
- c). If the modified program normally reads commands interactively when run, you must cause it, when started running for such interactive use in the most ordinary way, to print or display an announcement including an appropriate copyright notice and a notice that there is no warranty (or else, saying that you provide a warranty) and that users may redistribute the program under these conditions, and telling the user how to view a copy of this License. (Exception: if the Program itself is interactive but does not normally print such an announcement, your work based on the Program is not required to print an announcement.)

These requirements apply to the modified work as a whole. If identifiable sections of that work are not derived from the Program, and can be reasonably considered independent and separate works in themselves, then this License, and its terms, do not apply to those sections when you distribute them as separate works. But when you distribute the same sections as part of a whole which is a work based on the Program, the distribution of the whole must be on the terms of this License, whose permissions for other licensees extend to the entire whole, and thus to each and every part regardless of who wrote it.

Thus, it is not the intent of this section to claim rights or contest your rights to work written entirely by you; rather, the intent is to exercise the right to control the distribution of derivative or collective works based on the Program. In addition, mere aggregation of another work not based on the Program with the Program (or with a work based on the Program) on a volume of a storage or distribution medium does not bring the other work under the scope of this License.

3. You may copy and distribute the Program (or a work based on it, under Section 2) in object code or executable form under the terms of Sections 1 and 2 above provided that you also do one of the following:
 - a). Accompany it with the complete corresponding machine-readable source code, which must be distributed under the terms of Sections 1 and 2 above on a medium customarily used for software interchange; or,
 - b). Accompany it with a written offer, valid for at least three years, to give any third party, for a charge no more than your cost of physically performing source distribution, a complete machine-readable copy of the corresponding source code, to be distributed under the terms of Sections 1 and 2 above on a medium customarily used for software interchange; or,
 - c). Accompany it with the information you received as to the offer to distribute corresponding source code. (This alternative is allowed only for noncommercial distribution and only if you received the program in object code or executable form with such an offer, in accord with Subsection b above.)

The source code for a work means the preferred form of the work for making modifications to it. For an executable work, complete source code means all the source code for all modules it contains, plus any associated interface definition files, plus the scripts used to control compilation and installation of the executable. However, as a special exception, the source code distributed need not include anything that is normally distributed (in either source or binary form) with the major components (compiler, kernel, and so on) of the operating system on which the executable runs, unless that component itself accompanies the executable.

If distribution of executable or object code is made by offering access to copy from a designated place, then offering equivalent access to copy the source code from the same place counts as distribution of the source code, even though third parties are not compelled to copy the source along with the object code.

4. 4. You may not copy, modify, sublicense, or distribute the Program except as expressly provided under this License. Any attempt otherwise to copy, modify, sublicense or distribute the Program is void, and will automatically terminate your rights under this License. However, parties who have received copies, or rights, from you under this License will not have their licenses terminated so long as such parties remain in full compliance.
5. 5. You are not required to accept this License, since you have not signed it. However, nothing else grants you permission to modify or distribute the Program or its derivative works. These actions are prohibited by law if you do not accept this License. Therefore, by modifying or distributing the Program (or any work based on the Program), you indicate your acceptance of this License to do so, and all its terms and conditions for copying, distributing or modifying the Program or works based on it.
6. Each time you redistribute the Program (or any work based on the Program), the recipient automatically receives a license from the original licensor to copy, distribute or modify the Program subject to these terms

and conditions. You may not impose any further restrictions on the recipients' exercise of the rights granted herein. You are not responsible for enforcing compliance by third parties to this License.

7. If, as a consequence of a court judgment or allegation of patent infringement or for any other reason (not limited to patent issues), conditions are imposed on you (whether by court order, agreement or otherwise) that contradict the conditions of this License, they do not excuse you from the conditions of this License. If you cannot distribute so as to satisfy simultaneously your obligations under this License and any other pertinent obligations, then as a consequence you may not distribute the Program at all. For example, if a patent license would not permit royalty-free redistribution of the Program by all those who receive copies directly or indirectly through you, then the only way you could satisfy both it and this License would be to refrain entirely from distribution of the Program.

If any portion of this section is held invalid or unenforceable under any particular circumstance, the balance of the section is intended to apply and the section as a whole is intended to apply in other circumstances.

It is not the purpose of this section to induce you to infringe any patents or other property right claims or to contest validity of any such claims; this section has the sole purpose of protecting the integrity of the free software distribution system, which is implemented by public license practices. Many people have made generous contributions to the wide range of software distributed through that system in reliance on consistent application of that system; it is up to the author/donor to decide if he or she is willing to distribute software through any other system and a licensee cannot impose that choice.

This section is intended to make thoroughly clear what is believed to be a consequence of the rest of this License.

8. If the distribution and/or use of the Program is restricted in certain countries either by patents or by copyrighted interfaces, the original copyright holder who places the Program under this License may add an explicit geographical distribution limitation excluding those countries, so that distribution is permitted only in or among countries not thus excluded. In such case, this License incorporates the limitation as if written in the body of this License.
9. The Free Software Foundation may publish revised and/or new versions of the General Public License from time to time. Such new versions will be similar in spirit to the present version, but may differ in detail to address new problems or concerns.

Each version is given a distinguishing version number. If the Program specifies a version number of this License which applies to it and "any later version", you have the option of following the terms and conditions either of that version or of any later version published by the Free Software Foundation. If the Program does not specify a version number of this License, you may choose any version ever published by the Free Software Foundation.

10. If you wish to incorporate parts of the Program into other free programs whose distribution conditions are different, write to the author to ask for permission. For software which is copyrighted by the Free Software Foundation, write to the Free Software Foundation; we sometimes make exceptions for this. Our decision will be guided by the two goals of preserving the free status of all derivatives of our free software and of promoting the sharing and reuse of software generally.

NO WARRANTY

11. BECAUSE THE PROGRAM IS LICENSED FREE OF CHARGE, THERE IS NO WARRANTY FOR THE PROGRAM, TO THE EXTENT PERMITTED BY APPLICABLE LAW. EXCEPT WHEN OTHERWISE STATED IN WRITING THE COPYRIGHT HOLDERS AND/OR OTHER PARTIES PROVIDE THE PROGRAM "AS IS" WITHOUT WARRANTY OF ANY KIND, EITHER EXPRESSED OR IMPLIED, INCLUDING, BUT NOT LIMITED TO, THE IMPLIED WARRANTIES OF MERCHANTABILITY AND FITNESS FOR A PARTICULAR PURPOSE. THE ENTIRE RISK AS TO THE QUALITY AND PERFORMANCE OF THE PROGRAM IS WITH YOU. SHOULD THE PROGRAM PROVE DEFECTIVE, YOU ASSUME THE COST OF ALL NECESSARY SERVICING, REPAIR OR CORRECTION.

12. IN NO EVENT UNLESS REQUIRED BY APPLICABLE LAW OR AGREED TO IN WRITING WILL ANY COPYRIGHT HOLDER, OR ANY OTHER PARTY WHO MAY MODIFY AND/OR REDISTRIBUTE THE PROGRAM AS PERMITTED ABOVE, BE LIABLE TO YOU FOR DAMAGES, INCLUDING ANY GENERAL, SPECIAL, INCIDENTAL OR CONSEQUENTIAL DAMAGES ARISING OUT OF THE USE OR INABILITY TO USE THE PROGRAM (INCLUDING BUT NOT LIMITED TO LOSS OF DATA OR DATA BEING RENDERED INACCURATE OR LOSSES SUSTAINED BY YOU OR THIRD PARTIES OR A FAILURE OF THE PROGRAM TO OPERATE WITH ANY OTHER PROGRAMS), EVEN IF SUCH HOLDER OR OTHER PARTY HAS BEEN ADVISED OF THE POSSIBILITY OF SUCH DAMAGES.

END OF TERMS AND CONDITIONS

Appendix: How to Apply These Terms to Your New Programs

If you develop a new program, and you want it to be of the greatest possible use to the public, the best way to achieve this is to make it free software which everyone can redistribute and change under these terms.

To do so, attach the following notices to the program. It is safest to attach them to the start of each source file to most effectively convey the exclusion of warranty; and each file should have at least the "copyright" line and a pointer to where the full notice is found.

<one line to give the program's name and a brief idea of what it does.>

Copyright © 19yy <name of author>

This program is free software; you can redistribute it and/or modify it under the terms of the GNU General Public License as published by the Free Software Foundation; either version 2 of the License, or (at your option) any later version.

This program is distributed in the hope that it will be useful, but WITHOUT ANY WARRANTY; without even the implied warranty of MERCHANTABILITY or FITNESS FOR A PARTICULAR PURPOSE. See the GNU General Public License for more details.

You should have received a copy of the GNU General Public License along with this program; if not, write to the Free Software Foundation, Inc., 675 Mass Ave, Cambridge, MA 02139, USA.

Also add information on how to contact you by electronic and paper mail.

If the program is interactive, make it output a short notice like this when it starts in an interactive mode:

Gnomovision version 69, Copyright © 19yy name of author

Gnomovision comes with ABSOLUTELY NO WARRANTY; for details type `show w'. This is free software, and you are welcome to redistribute it under certain conditions; type `show c' for details.

The hypothetical commands `show w' and `show c' should show the appropriate parts of the General Public License. Of course, the commands you use may be called something other than `show w' and `show c'; they could even be mouse-clicks or menu items-whatever suits your program.

You should also get your employer (if you work as a programmer) or your school, if any, to sign a "copyright disclaimer" for the program, if necessary. Here is a sample; alter the names:

Yoyodyne, Inc., hereby disclaims all copyright interest in the program `Gnomovision' (which makes passes at compilers) written by James Hacker.

<signature of Ty Coon>, 1 April 1989

Ty Coon, President of Vice

This General Public License does not permit incorporating your program into proprietary programs. If your program is a subroutine library, you may consider it more useful to permit linking proprietary applications with the library. If this is what you want to do, use the GNU Library General Public License instead of this License.

Copyright

The XFree86 Project, Inc.

Copyright © 1994, 1995 The XFree86 Project, Inc. All Rights Reserved.

Permission is hereby granted, free of charge, to any person obtaining a copy of this software and associated documentation files (the "Software"), to deal in the Software without restriction, including without limitation the rights to use, copy, modify, merge, publish, distribute, sublicense, and/or sell copies of the Software, and to permit persons to whom the Software is furnished to do so, subject to the following conditions:

The above copyright notice and this permission notice shall be included in all copies or substantial portions of the Software.

THE SOFTWARE IS PROVIDED "AS IS", WITHOUT WARRANTY OF ANY KIND, EXPRESS OR IMPLIED, INCLUDING BUT NOT LIMITED TO THE WARRANTIES OF MERCHANTABILITY, FITNESS FOR A PARTICULAR PURPOSE AND NONINFRINGEMENT. IN NO EVENT SHALL THE XFREE86 PROJECT BE LIABLE FOR ANY CLAIM, DAMAGES OR OTHER LIABILITY, WHETHER IN AN ACTION OF CONTRACT, TORT OR OTHERWISE, ARISING FROM, OUT OF OR IN CONNECTION WITH THE SOFTWARE OR THE USE OR OTHER DEALINGS IN THE SOFTWARE.

Except as contained in this notice, the name of the XFree86 Project shall not be used in advertising or otherwise to promote the sale, use or other dealings in this Software without prior written authorization from the XFree86 Project.

\$XConsortium: CPYRIGHT.sgml,v 1.2 95/01/16 13:17:39 kaleb Exp \$

Generated from XFree86: xc/programs/Xserver/hw/xfree86/doc/sgml/CPYRIGHT.sgml,v 3.3 1995/01/28 16:01:20 dawes Exp \$

\$XFree86: xc/programs/Xserver/hw/xfree86/doc/COPYRIGHT,v 3.8 1995/07/24 06:52:11 dawes Exp \$

Index

Numerics

3D

FlipBook, 107

A

Absolute Colorimetric Rendering Intent, 59

Accuracy correction, 64

Accuracy of ICC Engine, 114

Add Slave

Cluster Manager, 102

Adding a Pagesetup Pool to a DropZone, 36

Adding a Pagesetup to a DropZone, 36

Adding a publication name

HowTo, 108

Adding Colours in Replace Colour Set, 77

Adding items from Archive to the Database, 105

Adding to an Archive

All, 104

Adding to Archive

Selection, 105

Adjusting a colour intensity in Virtual Press, 32

Adjusting colour intensity, 89

Agent, 80

Installing on Windows, 15

What's on the CD, 14

Angle of halftone dots, 61

Antialiasing, 58

Application Menu Items, 112

Applying a Border to a job, 63

Applying a watermark to a job, 63

Applying Cropmarks to a job, 63

Applying Linearisation Curve, 101

Archiver, 104

Adding All to archive, 104

Adding items to the database, 105

Adding Selection to archive, 105

Automatic Backup, 104

Exclude ICC Profiles, 105

Loading an Archive, 104

Performing a Full Backup, 104

Removing items from the archive, 105

Saving, 104

Authorisation, 112

Auto Clean, 54

Auto Paginate, 84

Auto Pause, 54

AutoFit - Signature Group, 86

Automated Backup, 104

AutoProofing, 81

Criteria, 82

AutoProofing Impose jobs or Single Pages only, 82

AutoProofing to multiple queues, 81

B

Backing up the database, 104

Bi-Cubic resampling, 62

Bi-Linear resampling, 62

Bleed, on a page

Signature Group, 86

Border around a job, 63

Bounding Box selection, 62

Broadcasting a Message, 113

C

Calibration

Backing up a Doublesided Proof, 140

Configuring a Pagesetup, 118

Measuring the Patches, 119

Overview, 118

Print Density Chart, 119

Sifting the Paper Profile values, 119

Calibration Guide, 118

Colour Management Diagram, 131

Correction LUT, 123

Creating a Paper Profile, 118

Dot Gain, 123

Expert Section, 123

ICC Profiles, 121

Assessing the chart, 122

Match Profile, 122

Ink Limits, 119

Linearisation, 120

Lineariser

Expert section, 129

Maximum Density Override, 130

Paper Profile

Assessing the Print, 125

Paper Profile Advanced

Choosing the Patches, 125

Evaluating Densities, 125

Grey Balance Vignette, 126

Practical Example, 127

Using the Graph, 126

Paper Profile patch table, 125

Printing the Linearisation Chart, 120

Reading the Linearisation Chart, 120

RGB Workflows, 123

Submitting the Linearisation Curve, 121

Summary, 129

Tuning the Calibration, 123

Tweak Set, 123

Yule Nielsen Number, 129

Cancelling a job, 33, 35

Centre Offset

Signature Group, 86

Centreing a job, 64

Change Pagesetup in Paper Profile, 68

Changing names in Replace Colour Set, 77

Changing the white point, 46

Changing Units, 114

Changing all plates in Soft Proof, 94

Channel Viewer for Soft Proof, 94

Chatter Box, 112

Nickname setting, 115

Choose Paper Colour in Soft Proof, 94

Choosing a Plate Colour in Virtual Press, 32

Choosing another Server, 112

CIP3

Exporting data, 93

Exporting information, 35

Clearing the RIP Job Cache, 30

Client

Finding hidden windows, 25

Overview, 24

Starting, 18

Client Log, 36

Changing Column view, 37

Filtering Messages, 37

Client Settings

Choose Match Profile, 115

Choose Monitor Profile, 115

Internationalisation, 114

Memory Cache Size, 115

Sound Effects, 114

Client settings, 114

Cluster Manager, 102

Manually adding a slave from a different subnet, 102

Master, 102

Pick processing pool, 102

Removing Offline Slaves, 102

Schedule Last, 102

Slaves, 102

Cluster Statu

Monitoring module, 38

Cluster Status

Changing the font size, 38

Increasing the size, 38

CMM Accuracy, 114

CMS Workflow Diagram, 131

CMYK ICC Profiles, 60

Collating, 55

Add separator page, 55

Duplexing with DoubleProof/SpinJet, 138

Colour Correction, 59

Colour Keys, 60

Colour Management Workflow Diagram, 131

Colour Space setting, 58

command script, 54

Compensating for media stretch, 64

Compensating for too light or dark a print, 42

Compression - System Settings, 114

Conditions

Regular Expression, 72

Configuration

- Setting up doublesided printing, 138
- Connect to another Server, 112
- Conversing between Remote sites, 112
- Copies
 - Changing the number, 33
 - correcting output size, 64
- Correction Curve, 59
- Correction LUT
 - Calibration Guide, 123
- Creating a new Paper Profile, 69
- Creating a Regular Expression
 - How to, 73
- Creating New Signatures, 85
- Cropmarks
 - Adding to a job, 63
- Cropping, 64
- Cropping an image in SoftProof, 94

D

- Decreasing the size of a DropSpot, 36
- Default ICC Profiles, 114
- Default rotation
 - SoftProof, 92
- Default zoom level
 - setting in SoftProof, 92
- De-impose
 - Printing the pagenumber on the page, 63
- Deimpose
 - Submitting jobs for De-Imposition, 30
- De-Imposing
 - Changing a Signature, 33
- De-imposing a job, 64
- Deimposition
 - Printing the page number and page line, 63
- de-imposition
 - Tolerances for auto mode, 87
- Deleting a job, 33
- Deleting a page
 - Signature Group, 86
- Deleting colours from Replace Colour Set, 76
- Deleting Signatures, 85
- Densitometer, 96
 - Activating an Instrument, 96
 - Exporting measurements, 96
 - Measuring target colours, 96
 - View Options, 97
 - Yule Nielsen Number, 96
- Descreening input data, 61
- Destination, 54
- Digital Blue Line in Soft Proof, 94
- Distributed Processing, 102
- Dongle
 - Licensed Bits, 22
 - What's on the CD, 14
- Dongle Driver
 - Installing on Windows, 14
- Dot Gain, 42
 - Applying to a Pagesetup, 59
 - Calibration Guide, 123
 - Colours in a Replace Colour Set, 77
 - Creating a new curve, 42
 - Entering values into a table, 42

- Showing the original curve, 42
- DotGain Curve on Special Colour, 89
- Dotgain Table
 - Entering values to create a curve, 42
- Dotshape, 61
- DoubleProof
 - Calibration test chart, 138
 - Configuration, 138
 - Configuring for double sided printing, 138
 - Printer Specifics, 140
- Doubleside Proofing
 - Limitations in backing up, 141
- Doublesided Proofing
 - Aligning front and back, 140
 - Submitting back page, 139
 - Submitting front page, 139
 - Test Page, 139
- Download PPD, 113
- Downloading data from Xrite Pulse, 137
- Drop Folders, 66
- Drop folders, 58
- Drop Zone
 - Edit Pagesetup., 36
- DropZone
 - Changing the font size, 36
 - Monitor Module, 36
- Duplex Queue Jobs
 - FlipBook, 106
- Duplexing, 55
 - Add a blank page between perfect bound jobs, 55
- Duplexing Control
 - DoubleProof/SpinJet, 138
- Duplexing jobs, 34
- Duplexing with DoubleProof/SpinJet, 138
- Duplicate Tab, 26
- Duplicating a page
 - Signature Group, 86
- Duplicating Signatures, 85
- DynaStrip, Importing signatures, 85

E

- Edit Pagesetup from a Drop Zone, 36
- Edit Signature
 - SoftProof, 92
- Editing
 - Output, 35
 - Pagesetup, 35
 - RIP, 35
 - Signature Group, 35
- Editing a Pagesetup, 67
- Editing an Output, 67
- Editing Colours
 - in Replace Colour Set, 77
- Editing the Pagesetup, 35
- Effects, 62
 - Adding signature information to the output, 63
- Entering a new polling Path, 81
- Entering strings, 72
- Epson Fire Wire, 54
- Error Diffusion Screening, 61
- Exact name matching in Replace Colour Set, 76

- Exclude ICC Profiles
 - Archiver, 105
- Export
 - CIP3, 35
 - Colours from Replace Colour Set, 77
 - Export job as Separated Postscript, 93
 - Export job as Tiff Multichannel, 35, 93
 - Export jobs as Separated Postscript, 35
 - Exporting CIP3 information, 93
 - Exporting Colours from Special Colour Set, 88
 - Exporting publication from FlipBook, 108
 - Exporting the Client Log to a file, 37
 - Exporting the Server log to a file, 37
 - Exporting values from the Densitometer, 96
 - Expressions, 72

F

- Facilis signatures, Importing, 85
- Fail on RGB Images, 62
- Fast Polling, 80
- Filter
 - Selecting a Regular Expression, 82
- Filtered resampling, 62
- Filtering jobs in the Queue Manager, 34
- Find and Replace
 - Replace Colour Set, 77
- Fit Height, 63
- Fit Width, 63
- Fitting Methods, 63
- FlipBook, 106
 - Borders, 108
 - Duplex Queue Jobs, 106
 - Export Movie
 - Codec Type, 108
 - Exporting as PDF, 108
 - Exporting as Quicktime Movie, 108
 - Exporting as Speads, 108
 - Keyframe Spacing, 108
 - Movie Quality, 108
 - Navigating through the book, 107
 - Page Order, 106
 - Pages, 107
 - Reload Publication, 108
 - Starting, 106
 - Swap page, 107
 - Thumbnails, 108
 - Viewing All Jobs, 106
 - Viewing in 3D, 107
- Flow Control
 - Hold after imaging
 - Virtual Press, 32
 - Hold after imaging from RIPMoitor, 31
 - Holding a job after imaging, 112
- FM Screening, 61
- FTP
 - Polling, 81
 - FTP Output, 54

G

- Gradation Curve, 44
 - Applying to a Pagesetup, 59
 - Enter values in a table, 44
 - How to create a new one, 44
 - Preview the curves, 44
 - Screen Printing, 133
 - View options, 44
- Gradation Table
 - Entering values for create a curve, 44
- Graph of the Paper Profile, 69
- Grid Attribute
 - Signature Group, 86
- Gripper size, 86
- Group by job, 31
- Group By Queue, 35
- Group pages
 - Signature Group, 84

H

- Haltone Screening, 61
- Head Position
 - Signature Group
 - Changing all at once, 87
- Hold after imaging
 - RIPMonitor, 31
 - Virtual Press, 32
- Holding a job, 33
- Holding a job after imaging, 112
- How To
 - Adjust the tint value of a special colour, 32
 - Apply Digital Blue Line in Soft Proof, 94
 - Create a new Signature, 87
 - Initiate a chat, 112
 - Measure something on the Soft Proof., 94
 - Read colours with Spectrophotometer into Special Colour Set, 89
 - Use the Densitometer Application, 97
 - Use the Spectrophotometer Application, 99
- How to
 - Create a Replace Colour Set for exact, Partial and Position, 76
 - Create a Replace Colour Set for Process Colours., 76
 - Create and apply a Regular Expression, 73
- HowTo
 - Adding a publication name to a job, 108
 - Calibrate your monitor, 110
 - Create a new Paper Profile, 69
 - Crop an Image and re-submit it, 95
 - Direct jobs to specific slaves, 102
 - Import a Signature, 87
 - Linearise with the Xrite Pulse, 136
 - Make a density measurement, 97

Use selective import in the Signature Group, 87

I

- ICC Correction to CMYK Specials, 114
- ICC Engine Accuracy, 114
- ICC Profile
 - Match, 115
 - Monitor, 115
 - Selecting Output Profile, 60
- ICC Profiles, 59
 - Assessing the Chart, 122
 - Calibration Guide, 121
 - Choosing input profile, 60
 - Copying into the system, 122
 - Defaults, 114
 - electing Rendering Intents, 59
 - Enabling in a Pagesetup, 59
 - Match Profile, 122
 - Retain Pure Black, 59
 - Spectrophotometer
 - Application, 98
- ICC Tweak Set, 46
- Ignore Items, 72
- Ignore Mod Time
 - RIPs, 80
- Imaging Thumbnail, 36
- Importing a signature
 - HowTo, 87
- Importing Colours
 - into Replace Colour Set, 77
- Importing colours to Special Colour Set, 88
- Importing Signatures, 85
- Imposition
 - Grouping pages, 84
- Impositions
 - Viewing the signature overlay in Soft Proof, 92
- Inclusive Page Grouping
 - Grouping pages in a signature, 85
- Increasing the size of a DropSpot, 36
- Ink Limiting
 - Enhanced, 69
 - Paper Profile, 69
 - Screen Printing, 133
 - Standard, 69
- InkLimit Chart, 68
- Input Filter, 80
- Input ICC Profile selection, 60
- Input Screening, 61
- Installing
 - Backing up version 2, 16
- Installing a Printer
 - Getting the PPD, 113
- Installing Serendipity Blackmagic
 - Macintosh, 16
 - Windows, 14
- Instant Messaging Nickname, 115
- Intermediate File Compression, 114
- Irix
 - What's on the CD, 14

J

- Japanese JIS Jobnaming Convention, 114
 - Japanese Jobnames - Viiewing, 114
 - JDF, Importing signature templates, 85
 - Job Genie, 48
 - Case Sensitive Matches, 49
 - Collecting files ready for sorting, 48
 - Displaying correctly in the RIPMonitor, 51
 - Filename Break Down, 49
 - Grouping jobs in the same directory, 50
 - Identifying Jobname and Plates, 50
 - Plate mapping, 51
 - Job Info
 - Adding to a printed job, 63
 - Customising what is displayed, 63
 - SoftProof, 92
 - Job info, 33, 35, 107
 - Jobs
 - Viewing in the RIPMonitor, 30
- K**
- Keeping original dots, 61
 - Keyframe Spacing
 - FlipBook, 108
 - Knockout, 77
 - Krause signatures, Importing, 85
- L**
- Language Encoding
 - Signature Group, 85
 - Language setting, 114
 - Left Align, 85
 - Linearisation
 - Screen Printing, 133
 - Linearisation Curve, 44
 - Applying to a Pagesetup, 59
 - Lineariser, 100
 - Choosing an Instrument, 100
 - Clearing Patches, 101
 - Expert Section, 129
 - Manual Entry, 101
 - Maximum Density Override, 130
 - Maximum Density Overrides, 101
 - Measuring patches, 100
 - Selecting a Pagesetup, 100
 - Submitting measurements, 101
 - Using the Xrite DTP20 Pulse, 136
 - Wizard, 100
 - Yule Nielsen, 101
 - Linux
 - What's on the CD., 14
 - Load Balancing, 66
 - Loading an Archive, 104
 - Localhost Polling, 81
 - Locking the Client to Prevent Changes, 112

Logging Poll Statistics, 80

Logo, 62

Loupe

SoftProof, 92

Low quality Thumbnail, 114

LPI, 61

M

MacOSX

What's on the CD, 14

Margins

adding, 64

Master machines, 102

Match all of the following

regular expression, 72

Match any of the following - regular expression, 72

Match ICC Profile, 115

Match Items, 72

Match List in Regular Expression, 72

Matching Colours through System Specials, 114

Maximum Density Override

Lineariser, 130

Maximum Density Overrides in Lineariser, 101

Maximum memory for PS RIP, 114

Maximum memory for Rotation, 114

Maximum Preview resolution, 115

Maximum Print Preview resolution, 114

Megarip PPD, 113

Memory Cache size for Soft Proof, 115

Minimum Plate Count, 82

Mirroring, 64

Mirroring a job, 63

Mirroring images in Soft Proof, 92

Modify the job

QueueManager, 33

Monitor, 25

Adding modules, 25

Edit mode, 25

Layout Options, 25

Loading a saved layout, 25

Rendering Thumbnail, 36

Saving a layout, 25

Show Imaging Thumbnail, 36

Tabs, 26

Changing Background Colour, 26

Choosing Background Image, 26

Creating, 26

Deleting, 26

Duplicate, 26

Renaming, 26

reordering, 26

Use mode, 25

Monitor ICC Profile, 115

Monitor Modules

Overview, 30

MonitorCalibrator, 110

Activating the device, 110

HowTo, 110

Profile Monitor, 110

Saving your profile, 110

Selecting the type of display, 110

Starting, 110

MonitorCalibrattor

Selecting a device, 110

N

Navigator window for Soft Proof, 93

Nearest Neighbour resampling, 62

Negating, 64

Negating an image in Soft Proof, 92

Negative, 63

Nesting, 56

Auto rotating at nesting time, 56

Nesting jobs, 34

New page

Signature Group, 86

Nickname, 112

Nowhere output destination, 55

O

Offset Page Number, 84

Signature Group, 85

Opaque, 77

Opening an Archive, 104

Ordered Dithered Screening, 61

Oueue Manager, 32

Output, 54

Selecting for a Pagesetup, 58

Output Colour space, 58

Output Customise settings, 58

Output ICC Profile, 60

Output resolution, 58

Output Screening, 61

Selection in Screen Print mode, 132

Overprint, 77

P

Page Boundary

Seeing the page area in Soft Proof, 92

Page Head direction

Signature Group, 86

Page Number, Changing

, 33

Pagenumber

displaying on the job, 63

Pages

Signature Group, 86

Pagesetup, 58

Colour Correction, 59

Colour Keys, 60

Correction Curve, 59

Dot Gain, 59

Effects, 62

ICC Profiles, 59

ICC Tweakset, 60

Input ICC Profile Selection, 60

Input Screening, 61

Linearisation Curve, 59

Logo, 62

Output ICC Profile, 60

Output screening, 61

Postscript Options, 62

Press Sheet Tolerances for auto de-

imposition, 87

Publishing, 58

Publishing as a printer, 59

Publishing TCP/IP Port, 59

Replace Colour Set, 59

Resampling, 62

Retain Pure Black, 59

Sheet, 63

Pagesetup Pool

Priority, 66

Publishing TCP/IP Port, 66

Pagesetup Pools, 66

Drop Folders, 66

Publishing, 66

Publishing as a Printer, 66

Paint Mode

Repace Colour Set, 77

Pair Pages

Signatures, 84

Pan

Soft Proof, 94

Paper Colour

Setting to none, 94

Paper Colour Emulation, 94

Paper Profile, 68

Advanced Configuration, 123

Calibration Guide

Grey Balance Vignette, 126

Using the Graph, 126

Change Pagesetup, 68

Choosing the patches, 125

Configuring a Pagesetup, 118

Creating a new one, 69

Enhanced Ink Limiting, 69

Example Charts, 124

Graph, 69

Manual Dot Selection, 123

Measuring Patches, 68

Patch Table, 125

Print Density Chart, 68

Printers Overview, 124

Printing InkLiimit Chart, 68

Screen Printing, 133

Setting InkLimits, 69

Sift Dot selection, 68

Sorting by Colour density, 68

Sorting by Patch Number, 68

Sorting by Visual Density, 68

Standard Ink Limiting, 69

The Patches, 68

Yule Nielsen, 69

Paper Profiles

Calibration Guide

Dot Ink Coverage, 126

Partial Name matching in Replace Colour Set, 76

Password Protection, 112

Patches of the Paper Profile, 68

Paths to RIP data, 81

Pause/Resume Printing, 33

Pausing a Queue, 35

PDF

Export from FlipBook, 108

Perceptual Rendering Intent, 59

Performing a Full Backup, 104

Pick processing pool

Directing jobs to specific slaves, 102

Plate attribute

Changing all at once, 87

Plate Options
Signature Group, 86

Plates
reordering in the Virtual Press, 32

Poll interval, 80

Polling, 80
Creating a RIP to Poll your jobs, 80
File Transfer Priority, 81
Ignore Mod Time, 80
Initiating a manual poll, 30
Logging statistics, 80
Method to use, 80
Path, 81
Testing configuration, 82
with FTP, 81

Polling Service Refresh, 114

Position matching in Replace Colour Set, 76

Postscript Options, 62

PPDs
Whats on the CD, 14

Preps signatures, Importing, 85

Preserving Dots from input Data, 61

Press Sheet Settings, 85

Preview Curves
Gradation Curve, 44

Preview Resolution, 114

Primer, 77

Print Density Chart, 68

Print Gallery, 34

Print Queue
Enabling, 54

Printer driver
Selecting, 54

Printing InkLimit Chart, 68

Printing the Pagenumber on the job, 63

Printing to a file, 54

Printing to a USB Printer, 55

Printing to a windows or Macintosh printer, 55

Printing to an AppleTalk Printer, 55

Printing to local printer, 54

Printing to multiple Pagesetups, 66

Printing via LPR, 55

Printing via TCP/IP, 55

Prioritising Jobs, 34

Priority, 58, 66

Process Colours in Replace Colour Set, 76

Profiling your monitor, 110

Progressive Proof, 60

Publication
Doublesided Proofing, 139

Publication Name
Adding to a job, 108
QueueManager, 33

Publishing
Pagesetup Pools, 66

Publishing a TCP/IP Port number, 59, 66

Publishing Pagesetups, 58

Publishing queues as printers, 59, 66

Q

Queue Manager
Allocating a queue colour, 34
Changing the font size, 35

Colour Scheme, 35

Configure Toolbar, 33

List Colour, 35

Pause Printing, 33

Resume Printing, 33

View Options, 32

Queue Priority, 58

Queue Status
Changing the Font size, 36
Changing the Queue it monitors, 35
Monitor Module, 35
Queue Order, 36

QueueManager
Changing a Signature, 33
Changing the name of a job, 33
Changing the number of copies, 33
Changing the page number, 33
Modifying
Publication name, 109
Modifying the job., 33
Publication Name, 33
View FlipBook, 106

QUickTime
Keyframe Spacing, 108

QuickTime Movie
Exporting from FlipBook, 108

QuickTime Quality
Exporting from FlipBook, 108

Quitting the Client, 113

R

RDT - Real Dot Technology, 61

Referrers
Showing item usage, 24

Regular Expression, 72
How to, 73
Ignore Items, 72
Match All, 72
Match Any, 72
Match Items, 72
Selecting in RIP, 82
String Entry, 72
What is it?, 72

Relative Colorimetric Rendering Intent, 59

Releasing a job, 33

Reload Publication
FlipBook, 108

Removing a DropSpot, 36

Removing dots from input data, 61

Removing items from the Archive, 105

Removing offline Slaves, 102

rename signature, 84

Renaming a Job in Virtual Press, 31

Renaming Colours in Replace Colour Set, 77

Renaming colours in Special Colour Set, 88

Rendering a job again., 34

Rendering Intent
Spectrophotometer, 98

Rendering Intents
Changing for a Pagesetup, 59

Rendering Thumbnail, 36

Replace Colour Set, 76
Adding Colours, 77

Applying to a Pagesetup, 59

Creating for Exact and Partial Names and Position, 76

Creating New Colour, 76

Dot Gain, 77

Entering data for Process Colours, 76

Exporting Colours, 77

Importing Colours, 77

Paint Mode, 77

Process Colours, 76

Resampling, 62
Bi-Cubic, 62
B-Linear, 62
Effects of, 62
Filtered, 62
Nearest Neighbour, 62
Usage, 62

Resolution
Preview, 114
Soft Proof Application, 115

Resolution setting, 58

Restoring a database from an Archive, 105

Resubmitting a job to print, 33

Resuming a Queue processing, 35

Retain Pure Black, 59

Retrying failed jobs, 33

Reverse page viewing
Seeing the reverse page though the top, 92

Reverting Plates in Soft Proof, 94

RGB
Failing in PS Jobs, 62

RGB ICC Profiles, 60

RGB Workflows
Calibration Guide, 123

RIP, 80
AutoProofing, 81
Driver selection, 80
Editing a configuration, 30
Ignore Mod Time, 80
Paths, 81
Polling, 80
Turning Polling on/off, 30

RIPMonitor, 30, 31
Changing the font size, 30
Hold after imaging, 31
Showing a jobs plates, 30
Viewing imposed jobs only, 31

RIPs
Displaying more than one, 30
Selecting another RIP to View, 30

Rotate jobs
Nesting, 56

Rotating a job, 64

Rotating all signature
Signature Group, 87

Rotating Images in Soft Proof, 92

Rotating Signatures, 84

Rotating signatures, 85

Rotation
Setting the default for SoftProof, 92

Rush Jobs, 34

S

- Saturation Rendering Intent, 59
- Save Serendipity Blackmagic Image file
 - SoftProof, 93
- Saving an Archive, 104
- Saving Linearisation data, 101
- Saving output to a folder, 54
- Saving the database, 104
- Scale output, 63
- Scan and Print
 - SoftProof, 93
- Schedule Last
 - Clustering, 102
- Screen Angle, 61
- Screen Angles
 - Screen Printing, 133
- Screen Printing, 60, 132
 - Colour space selection, 132
 - Configuration, 132
 - Ink Limiting, 133
 - Linearisation, 133
 - Output Screening, 132
 - Paper Profile, 133
 - Selection in PageSetup, 132
 - Supercell, 133
- Screen Ruling, 61
- Screening
 - Error Diffusion, 61
 - FM, 61
 - Halftone, 61
 - LPI, 61
 - Ordered Dithered, 61
 - Screen Printing mode, 132
 - Stochastic, 61
 - SuperCell, 61
- Search
 - SoftProof Channel Viewer, 94
- Searching for jobs in RIPMonitor, 31
- Searching for jobs in the Queue Manager, 34
- Searching for messages in the Client Log, 37
- Searching for messages in the Server Log, 38
- Selecting another Server, 112
- Selecting System Specials, 114
- Selective Import
 - Choosing your signatures to import into Signature Group, 85
- Sending a job to another Pagesetup, 34
- Separated Postscript, 35, 93
- Separator page
 - Adding a blank page in a duplexed job, 55
- Serendipity Blackmagic
 - Creating Doc Icons Macintosh, 16
- Serendipity Client
 - What's on the CD, 14
- Server
 - Automatically starting on Launch, 22
 - Overview, 22
 - Quitting, 22
 - Restarting, 22
 - Restarting after a Crash, 22
 - Starting, 18, 22
 - Starting in safe mode, 22
 - Stopping, 22
- Server Info, 115
- Server Log, 37
 - Changing columns view, 38
 - Filtering the messages, 38
- Server Maintenance
 - Broadcasting a message, 113
- Server Setting
 - Maximum memory settings, 114
- Server Settings, 114
 - Apply ICC correction to CMYK Specials, 114
 - Default ICC Profiles, 114
 - Language encoding for Jobnames, 114
 - Polling Service Refresh, 114
- Setting interface language, 114
- Setting preview resolution, 114
- Sheduled Backup, 104
- Sheet Attributes, 63
- Showing multiple queues in the Queue Manager, 33
- Shrink to Fit Height and Width, 63
- Shrinking to fit a width, 63
- Shrinking to fit height, 63
- Sift, 68
- Signature
 - Delete, 85
 - Duplicating, 85
 - New, 85
 - Printing Pagenumber on the page, 63
- Signature Decoration
 - Printing lines and page numbers, 63
- Signature Goup
 - Selective Import, 85
- Signature Group, 84
 - Adding a page number, 86
 - Auto Paginate, 84
 - AutoFit, 86
 - Changing page orientation, 86
 - Deleting a page, 86
 - Display Options, 85
 - Duplicating a page, 86
 - Editing Page Numbers, 84
 - Find and Replace, 84
 - Grid Attributes, 86
 - Gripper Size, 86
 - Grouping pages, 85
 - Grouping pages together, 84
 - Importing Signatures, 85
 - Language encoding, 85
 - Left Align, 85
 - Multi-selectiing signatures, 85
 - Offset Page Number, 84, 85
 - Page Attributes, 86
 - Page head direction, 86
 - Pair Pages, 84
 - Pair Pages Vertically, 84
 - Pairing on all signature simultaneously, 87
 - Placing a new page, 86
 - Plate Options, 86
 - Press Sheet Settings, 85
 - rename, 84
 - Rotating, 84
 - Rotating the group, 85
 - Setting page height, 86
- Setting the gutter, 86
- Setting the number of columns, 86
- Setting the number of rows, 86
- Setting the page size, 86
- Settings page width, 86
- Suppressing Page, 84
- Tool Bar, 84
- Top Align, 85
- Ungrouping of pages, 84
- Signature Groups
 - Pair Pages Horizontally, 84
- Signature Overlay
 - Viewing in Soft Proof, 92
- Signatures, 85
- Simple RGB to CMYK Conversion, 62
- Slaves, 102
 - Starting server as a slave, 22
- Slug line, 62
- Slugline
 - Customising, 63
- Soft Proof, 92
 - Adjusting the intensity of colours, 94
 - Applying a Replace Colour Set, 94
 - Channel Viewer, 93, 94
 - Choose Paper Colour, 94
 - Loading Image Files, 93
 - Maximum Preview Resolution, 114, 115
 - Measure, 94
 - Memory Cache setting, 115
 - Mirror, 92
 - Navigator Window, 93
 - Negative, 92
 - Pan mode, 94
 - Reverting plates, 94
 - Rotate, 92
 - Setting transparency level for reverse page viewing, 92
 - Submit, 93
 - Swapping Plates, 94
 - Turning plates off, 93
 - View Options, 92
 - Viewing the page area, 92
 - Viewing the reverse page, 92
 - Viewing the signature over the imposition, 92
 - Zoom, 92
- SoftProof
 - Cropping an image, 94
 - Default rotation, 92
 - Default zoom level, 92
 - Editing a Signature, 92
 - Job Info, 92
 - Loupe, 92
 - Save Serendipity Blackmagic Image file, 93
 - Search for plates, 94
 - Starting, 92
 - Thumbnail, 92
- Softproof
 - Zoom into an area, 94
- solaris
 - What's on the CD, 14
- Sound Effects, 114
- Special Colour Set, 88

Adding Colours from library, 88
 Colour Adjustment, 89
 Deleting Colours, 88
 DotGain Curve, 89
 Duplicating Colours, 88
 Entering a New Colour, 88
 Exporting Colours, 88
 Importing Colours, 88
 Importing Colours from Spectrophotometer, 8
 9
 Renaming Colours, 88
 Setting Paint Modes, 89
 Setting the Tint, 89
 System Setting, 114
 View Options, 89
 Spectrophotometer, 98
 Entering colours in the Replace Colour Set, 78
 Exporting Values, 98
 Importing colours direct to Special Colour Set, 89
 Load Set, 98
 Selecting a device, 98
 View Columns, 98
 SpectrophotometerSetting ICC Profiles, 98
 SpinJet
 Configuration, 138
 Configuring for double sided printing, 138
 Printer Specifics, 140
 Status
 Changing font size, 36
 Viewing Disk space, 36
 Stochastic Screening, 61
 Strings
 applying rules, 72
 Stripe Paths, 81
 Submit
 Holding after imaging, 112
 Submit with Changes in Soft Proof, 93
 Submitting a job
 Doublesided proofing, 139
 Submitting a job
 Publication name, 108
 Submitting Files for
 Deimposirion, 112
 Submitting Files to Print, 112
 Submitting jobs for processing, 30
 Submitting Test Prints, 112
 Supercell
 Screen Printing, 133
 SuperCell Screening, 61
 Supercell screening angles
 Offset 7.5 degrees, 133
 Suppressing Pages
 Signatrure Group, 84
 Swapping Plates on Soft Proof, 94
 System Settings, 114
 Compression, 114

T

Tabs
 re-ordering, 26
 TCP/IP Port, 59
 Test Page
 DoubleSided Proofing, 139

Test Prints, 112
 Testing Poll configuration, 82
 TestPrints
 What's on the CD, 14
 Thumbnail, 36
 Changing the size, 36
 Choosing the quality, 114
 Rendering Thumbnail, 36
 SoftProof, 92
 thumbnail preview, 33, 107
 Tiff Multichannel - Export, 35, 93
 Tiling a job, 63
 Tint
 Adjusting the intensity of colours in the Special Colour Set, 89
 Tint value
 Soft Proof, 94
 Virtual Press
 Adjusting the intensity, 32
 Top Align, 85
 Transparency, 77
 Setting level of show through on reverse page viewing in Soft Proof, 92
 Trim lines
 adding to the output, 63
 Trimming the Client Log, 37
 Trimming the Server Log file, 37
 Turning Sound Effects on/off, 114
 Tutorial - Running the software, 18
 Twain Acquire
 Scan and Print, 93
 Tweak Set
 Calibration Guide, 123
 Creating a Tweak, 46
 How to create a new Tweak Set, 46
 Selecting for a Pagesetup, 60
 Tweaking Colour, 46

U

Ungrouping of pages
 Signature Group, 84
 Units, 114
 Upgrading Serendipity Blackmagic
 Macintosh, 16
 Windows, 15

V

View FlipBook, 106
 Viewing errors, 34
 Viewing the Imaged job, 34, 107
 Viewing the Rendered job, 34, 107
 Virtual Loupe
 SoftProof, 92
 Virtual Press, 31
 Adjusting the Tint value of a colour., 32
 History, 31
 Hold after imaging, 32
 Visual Density, 68

W

Watermark
 Adding to a job, 63
 windows
 What's on the CD, 14
 Workbench, 24
 Changing the view, 25
 Creating a new item, 24
 Deleting an item, 24
 Making a copy, 24
 Saving a configuration, 24

X

Xrite DTP20 Pulse
 Making a linearisation, 136

Y

Yule Nielsen, 69
 Yule Nielsen Number
 Calibration Guide, 129
 Densitometer, 96
 Effects, 101
 Yule Nielson NUmber
 Lineariser, 101

Z

Zoom in on an area in Softproof, 94
 Zoom level
 setting the default for SoftProof, 92
 Zooming in/out in Soft Proof, 92

